



Standard Test Method for Distillation of Petroleum Products at Atmospheric Pressure¹

This standard is issued under the fixed designation D 86; the number immediately following the designation indicates the year of original adoption or, in the case of revision, the year of last revision. A number in parentheses indicates the year of last reapproval. A superscript epsilon (ϵ) indicates an editorial change since the last revision or reapproval.

This standard has been approved for use by agencies of the Department of Defense.

1. Scope*

1.1 This test method covers the atmospheric distillation of petroleum products using a laboratory batch distillation unit to determine quantitatively the boiling range characteristics of such products as natural gasolines, light and middle distillates, automotive spark-ignition engine fuels, aviation gasolines, aviation turbine fuels, 1-D and 2-D regular and low sulfur diesel fuels, special petroleum spirits, naphthas, white spirits, kerosenes, and Grades 1 and 2 burner fuels.

1.2 The test method is designed for the analysis of distillate fuels; it is not applicable to products containing appreciable quantities of residual material.

1.3 This test method covers both manual and automated instruments.

NOTE 1—Interlaboratory consensus test data have been obtained in the last few years under the CS92 program. The statistical equivalency between the manual and the automated procedure is currently under study, based on data from this program obtained between 1994 and 1998.

1.4 Unless otherwise noted, the values stated in SI units are to be regarded as the standard. The values given in parentheses are provided for information only.

1.5 *This standard does not purport to address all of the safety concerns, if any, associated with its use. It is the responsibility of the user of this standard to establish appropriate safety and health practices and determine the applicability of regulatory limitations prior to use.*

2. Referenced Documents

2.1 All standards are subject to revision, and parties to agreement on this test method are to apply the most recent edition of the standards indicated below, unless otherwise specified, such as in contractual agreements or regulatory rules where earlier versions of the method(s) identified may be required.

2.2 ASTM Standards:

- D 97 Test Method for Pour Point of Petroleum Products²
 - D 323 Test Method for Vapor Pressure of Petroleum Products (Reid Method)²
 - D 2892 Test Method for Distillation of Crude Petroleum (15-Theoretical Plate Column)²
 - D 4057 Practice for Manual Sampling of Petroleum and Petroleum Products³
 - D 4177 Practice for Automatic Sampling of Petroleum and Petroleum Products³
 - D 4953 Test Method for Vapor Pressure of Gasoline and Gasoline-Oxygenate Blends (Dry Method)³
 - D 5190 Test Method for Vapor Pressure of Petroleum Products (Automatic Method)³
 - D 5191 Test Method for Vapor Pressure of Petroleum Products (Mini Method)³
 - D 5482 Test Method for Vapor Pressure of Petroleum Products (Mini Method-Atmospheric)⁴
 - D 5949 Test Method for Pour Point of Petroleum Products (Automatic Pressure Pulsing Method)⁴
 - D 5950 Test Method for Pour Point of Petroleum Products (Automatic Tilt Method)⁴
 - D 5985 Test Method for Pour Point of Petroleum Products (Rotational Method)⁴
 - E 1 Specification for ASTM Thermometers⁵
 - E 77 Test Method for Inspection and Verification of Thermometers⁵
 - E 1272 Specification for Laboratory Glass Graduated Cylinders⁶
 - E 1405 Specification for Laboratory Glass Distillation Flasks⁶
- 2.3 *IP Standards:*⁷
- IP 69 Determination of Vapour Pressure—Reid Method
 - IP 123 Petroleum Products—Determination of Distillation Characteristics
 - IP 394 Determination of Air Saturated Vapour Pressure

¹ This test method is under the jurisdiction of ASTM Committee D02 on Petroleum Products and Lubricants and is the direct responsibility of Subcommittee D02.08 on Volatility.

In the IP, the equivalent test method is published under the designation IP 123. It is under the jurisdiction of the Standardization Committee.

Current edition approved June 10, 2003. Published August 2003. Originally approved in 1921. Last previous edition approved in 2002 as D 86-02.

² *Annual Book of ASTM Standards*, Vol 05.01.

³ *Annual Book of ASTM Standards*, Vol 05.02.

⁴ *Annual Book of ASTM Standards*, Vol 05.03.

⁵ *Annual Book of ASTM Standards*, Vol 14.03.

⁶ *Annual Book of ASTM Standards*, Vol 14.04.

⁷ Available from the Institute of Petroleum, 61 New Cavendish St., London, W1G 7AR, UK.

***A Summary of Changes section appears at the end of this standard.**

3. Terminology

3.1 Definitions:

3.1.1 *charge volume, n*—the volume of the specimen, 100 mL, charged to the distillation flask at the temperature specified in Table 1.

3.1.2 *decomposition, n—of a hydrocarbon*, the pyrolysis or cracking of a molecule yielding smaller molecules with lower boiling points than the original molecule.

3.1.2.1 *decomposition point, n*—the corrected thermometer reading that coincides with the first indications of thermal decomposition of the liquid in the flask.

(1) *Discussion*—Characteristic indications of thermal decomposition are evolution of fumes and erratic temperature readings that usually decrease after any attempt is made to adjust the heat.

NOTE 2—The decomposition point, as determined under the conditions of this test method, does not necessarily correspond to the decomposition temperature in other applications.

3.1.3 *dry point, n*—the corrected thermometer reading that is observed at the instant the last drop of liquid (exclusive of any drops or film of liquid on the side of the flask or on the temperature sensor), evaporates from the lowest point in the distillation flask.

3.1.3.1 *Discussion*—The end point (final boiling point), rather than the dry point, is intended for general use. The dry point can be reported in connection with special purpose naphthas, such as those used in the paint industry. Also, it is substituted for the end point (final boiling point) whenever the sample is of such a nature that the precision of the end point (final boiling point) cannot consistently meet the requirements given in the precision section.

3.1.4 *dynamic holdup, n*—the amount of material present in the neck of the flask, in the sidearm of the flask, and in the condenser tube during the distillation.

3.1.5 *emergent stem effect, n*—the offset in temperature reading caused by the use of total immersion Hg-in-glass thermometers in the partial immersion mode.

3.1.5.1 *Discussion*—In the partial immersion mode, a portion of the mercury thread, that is, the emergent portion, is at

a lower temperature than the immersed portion, resulting in a shrinkage of the mercury thread and a lower temperature reading.

3.1.6 *end point (EP) or final boiling point (FBP), n*—the maximum corrected thermometer reading obtained during the test.

3.1.6.1 *Discussion*—This usually occurs after the evaporation of all liquid from the bottom of the flask. The term maximum temperature is a frequently used synonym.

3.1.7 *front end loss, n*—loss due to evaporation during transfer from receiving cylinder to distillation flask, vapor loss during the distillation, and uncondensed vapor in the flask at the end of the distillation.

3.1.8 *initial boiling point (IBP), n*—the corrected thermometer reading that is observed at the instant the first drop of condensate falls from the lower end of the condenser tube.

3.1.9 *percent evaporated, n*—the sum of the percent recovered and the percent loss.

3.1.10 *percent loss (or observed loss), n*—one hundred minus the percent total recovery.

3.1.10.1 *corrected loss, n*—percent loss corrected for barometric pressure.

3.1.11 *percent recovered, n*—the volume of condensate observed in the receiving cylinder, expressed as a percentage of the charge volume, associated with a simultaneous temperature reading.

3.1.12 *percent recovery, n*—the maximum percent recovered, as observed in accordance with 10.14.

3.1.12.1 *corrected percent recovery, n*—the percent recovery, adjusted for the difference between the observed loss and the corrected loss, as described in Eq 8.

3.1.12.2 *percent total recovery, n*—the combined percent recovery and residue in the flask, as determined in accordance with 11.1.

3.1.13 *percent residue, n*—the volume of residue in the flask, measured in accordance with 10.19, and expressed as a percentage of the charge volume.

3.1.14 *rate of change (or slope), n*—the change in temperature reading per percent evaporated or recovered, as described in 13.2.

TABLE 1 Preparation of Apparatus

	Group 0	Group 1	Group 2	Group 3	Group 4
Flask, mL	100	125	125	125	125
ASTM distillation thermometer	7C (7F)	7C (7F)	7C (7F)	7C (7F)	8C (8F)
IP distillation thermometer range	low	low	low	low	high
Flask support board	A	B	B	C	C
diameter of hole, mm	32	38	38	50	50
Temperature at start of test					
Flask					
°C	0–5	13–18	13–18	13–18	not above
°F	32–40	55–65	55–65	55–65	ambient
Flask support and shield	not above ambient	not above ambient	not above ambient	not above ambient	
Receiving cylinder and 100 mL charge					
°C	0–5	13–18	13–18	13–18 ^A	13–ambient ^A
°F	32–40	55–65	55–65	55–65 ^A	55–ambient ^A

^A See 10.3.1.1 for exceptions.

3.1.15 *temperature lag, n*—the offset between the temperature reading obtained by a temperature sensing device and the true temperature at that time.

3.1.16 *temperature measurement device, n*—a thermometer, as described in 6.3.1, or a temperature sensor, as described in 6.3.2.

3.1.17 *temperature reading, n*—the temperature obtained by a temperature measuring device or system that is equal to the thermometer reading described in 3.1.18.

3.1.17.1 *corrected temperature reading, n*—the temperature reading, as described in 3.1.17, corrected for barometric pressure.

3.1.18 *thermometer reading (or thermometer result), n*—the temperature of the saturated vapor measured in the neck of the flask below the vapor tube, as determined by the prescribed thermometer under the conditions of the test.

3.1.18.1 *corrected thermometer reading, n*—the thermometer reading, as described in 3.1.18, corrected for barometric pressure.

4. Summary of Test Method

4.1 Based on its composition, vapor pressure, expected IBP or expected EP, or combination thereof, the sample is placed in one of five groups. Apparatus arrangement, condenser temperature, and other operational variables are defined by the group in which the sample falls.

4.2 A 100-mL specimen of the sample is distilled under prescribed conditions for the group in which the sample falls. The distillation is performed in a laboratory batch distillation unit at ambient pressure under conditions that are designed to provide approximately one theoretical plate fractionation. Systematic observations of temperature readings and volumes of condensate are made, depending on the needs of the user of the data. The volume of the residue and the losses are also recorded.

4.3 At the conclusion of the distillation, the observed vapor temperatures can be corrected for barometric pressure and the data are examined for conformance to procedural requirements, such as distillation rates. The test is repeated if any specified condition has not been met.

4.4 Test results are commonly expressed as percent evaporated or percent recovered versus corresponding temperature, either in a table or graphically, as a plot of the distillation curve.

5. Significance and Use

5.1 The basic test method of determining the boiling range of a petroleum product by performing a simple batch distillation has been in use as long as the petroleum industry has existed. It is one of the oldest test methods under the jurisdiction of ASTM Committee D02, dating from the time when it was still referred to as the Engler distillation. Since the test method has been in use for such an extended period, a tremendous number of historical data bases exist for estimating end-use sensitivity on products and processes.

5.2 The distillation (volatility) characteristics of hydrocarbons have an important effect on their safety and performance, especially in the case of fuels and solvents. The boiling range gives information on the composition, the properties, and the

behavior of the fuel during storage and use. Volatility is the major determinant of the tendency of a hydrocarbon mixture to produce potentially explosive vapors.

5.3 The distillation characteristics are critically important for both automotive and aviation gasolines, affecting starting, warm-up, and tendency to vapor lock at high operating temperature or at high altitude, or both. The presence of high boiling point components in these and other fuels can significantly affect the degree of formation of solid combustion deposits.

5.4 Volatility, as it affects rate of evaporation, is an important factor in the application of many solvents, particularly those used in paints.

5.5 Distillation limits are often included in petroleum product specifications, in commercial contract agreements, process refinery/control applications, and for compliance to regulatory rules.

6. Apparatus

6.1 Basic Components of the Apparatus:

6.1.1 The basic components of the distillation unit are the distillation flask, the condenser and associated cooling bath, a metal shield or enclosure for the distillation flask, the heat source, the flask support, the temperature measuring device, and the receiving cylinder to collect the distillate.

6.1.2 Figs. 1 and 2 and are examples of manual distillation units.

6.1.3 In addition to the basic components described in 6.1.1, automated units also are equipped with a system to measure and automatically record the temperature and the associated recovered volume in the receiving cylinder.

6.2 A detailed description of the apparatus is given in Annex A2.

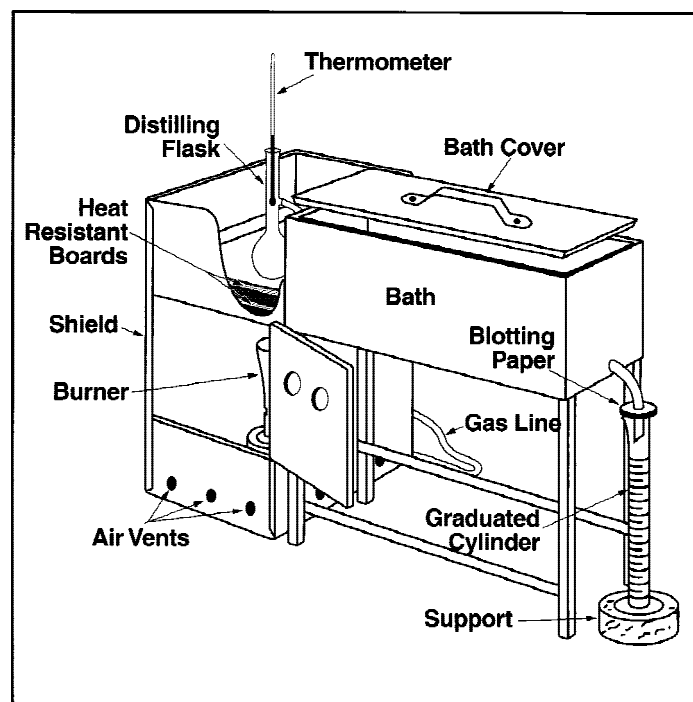
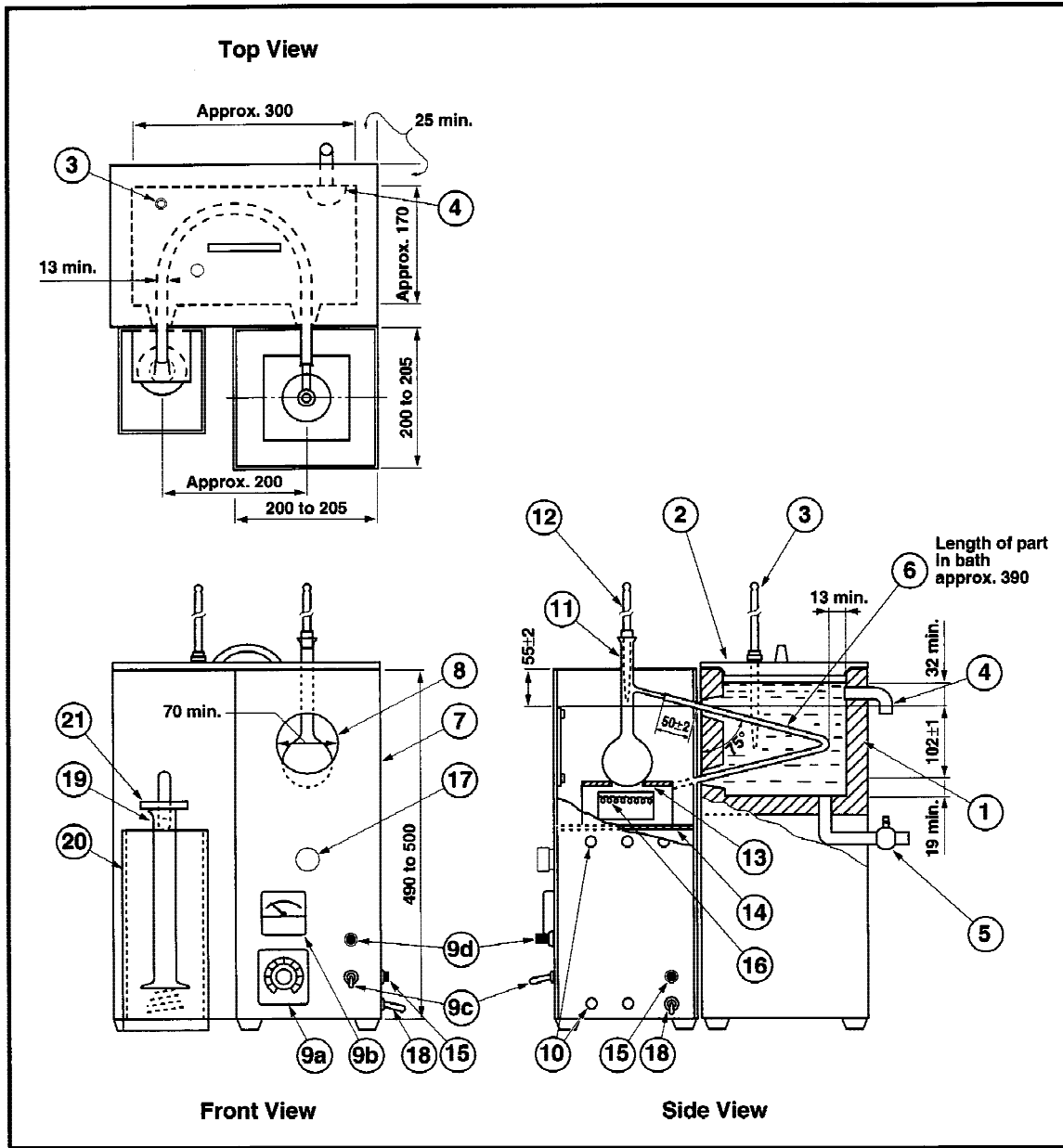

FIG. 1 Apparatus Assembly Using Gas Burner



NOTE 1—Legend:

- | | |
|---------------------------|---|
| 1—Condenser bath | 11—Distillation flask |
| 2—Bath cover | 12—Temperature sensor |
| 3—Bath temperature sensor | 13—Flask support board |
| 4—Bath overflow | 14—Flask support platform |
| 5—Bath drain | 15—Ground connection |
| 6—Condenser tube | 16—Electric heater |
| 7—Shield | 17—Knob for adjusting level of support platform |
| 8—Viewing window | 18—Power source cord |
| 9a—Voltage regulator | 19—Receiver cylinder |
| 9b—Voltmeter or ammeter | 20—Receiver cooling bath |
| 9c—Power switch | 21—Receiver cover |
| 9d—Power light indicator | |
| 10—Vent | |

FIG. 2 Apparatus Assembly Using Electric Heater

6.3 Temperature Measuring Device:

6.3.1 Mercury-in-glass thermometers, if used, shall be filled with an inert gas, graduated on the stem and enamel backed.

They shall conform to Specification E 1 or IP Standard Methods for Analysis and Testing of Petroleum and Related Products 1996, Appendix A, or both, for thermometers ASTM

7C/IP 5C and ASTM 7F for the low range thermometers, and ASTM 8C/IP 6C and ASTM 8F for the high range thermometers.

6.3.1.1 Thermometers that have been exposed for an extended period above an observed temperature of 370°C shall not be reused without a verification of the ice point or checked as prescribed in Specification E 1 and Test Method E 77.

NOTE 3—At an observed thermometer reading of 370°C, the temperature of the bulb is approaching a critical range in the glass and the thermometer may lose its calibration.

6.3.2 Temperature measurement systems other than those described in 6.3.1 are satisfactory for this test method, provided that they exhibit the same temperature lag, emergent stem effect, and accuracy as the equivalent mercury-in-glass thermometer.

6.3.2.1 The electronic circuitry or the algorithms, or both, used shall include the capability to simulate the temperature lag of a mercury-in-glass thermometer.

6.3.2.2 Alternatively, the sensor can also be placed in a casing with the tip of the sensor covered so that the assembly, because of its adjusted thermal mass and conductivity, has a temperature lag time similar to that of a mercury-in-glass thermometer.

NOTE 4—In a region where the temperature is changing rapidly during the distillation, the temperature lag of a thermometer can be as much as 3 seconds.

6.3.3 In case of dispute, the referee test method shall be carried out with the specified mercury-in-glass thermometer.

6.4 Temperature Sensor Centering Device:

6.4.1 The temperature sensor shall be mounted through a snug-fitting device designed for mechanically centering the sensor in the neck of the flask without vapor leakage. Examples of acceptable centering devices are shown in Figs. 3 and 4. (**Warning**—The use of a plain stopper with a hole drilled through the center is not acceptable for the purpose described in 6.4.1.)

NOTE 5—Other centering devices are also acceptable, as long as they position and hold the temperature sensing device in the proper position in the neck of the distillation column, as shown in Fig. 5 and described in 10.5.

NOTE 6—When running the test by the manual method, products with

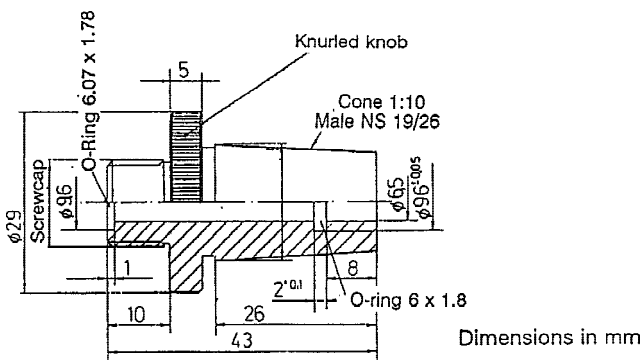

FIG. 3 PTFE Centering Device for Ground Glass Joint

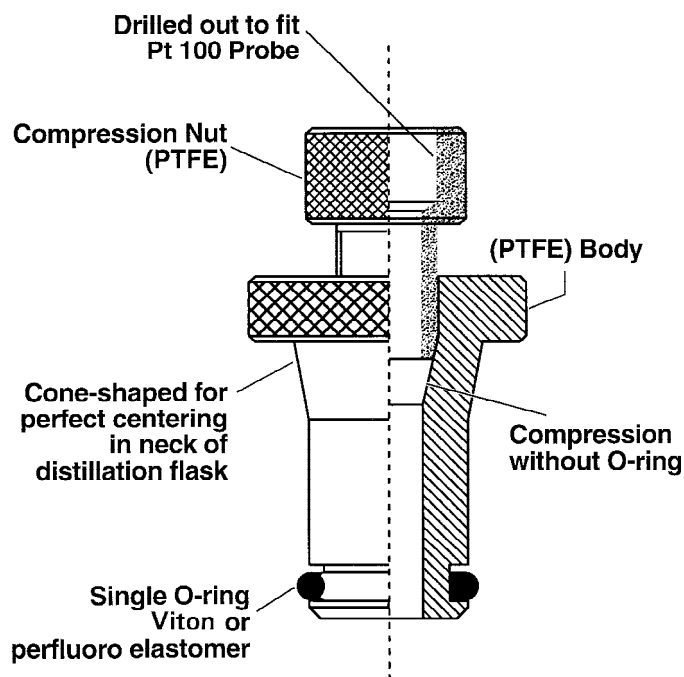

FIG. 4 Example of Centering Device Designs for Straight-Bore Neck Flasks

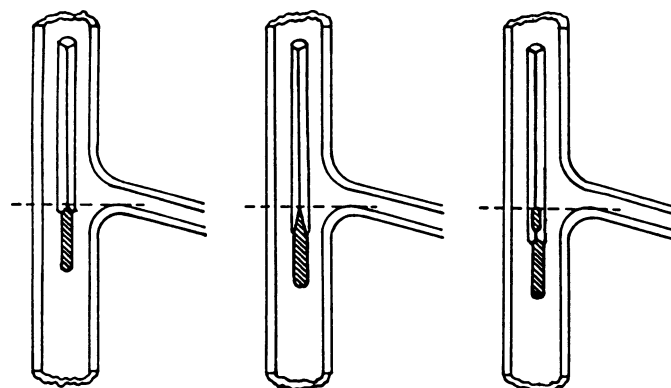

FIG. 5 Position of Thermometer in Distillation Flask

a low IBP may have one or more readings obscured by the centering device. See also 10.14.4.1.

6.5 Automated equipment manufactured in 1999 and later shall be equipped with a device to automatically shut down power to the unit and to spray an inert gas or vapor in the chamber where the distillation flask is mounted in the event of fire.

NOTE 7—Some causes of fires are breakage of the distillation flask, electrical shorts, and foaming and spilling of liquid sample through the top opening of the flask.

6.6 Barometer—A pressure measuring device capable of measuring local station pressure with an accuracy of 0.1 kPa (1 mm Hg) or better, at the same elevation relative to sea level as the apparatus in the laboratory. (**Warning**—Do not take readings from ordinary aneroid barometers, such as those used

at weather stations and airports, since these are precorrected to give sea level readings.)

7. Sampling, Storage, and Sample Conditioning

7.1 Determine the Group characteristics that correspond to the sample to be tested (see Table 2). Where the procedure is dependent upon the group, the section headings will be so marked.

7.2 Sampling:

7.2.1 Sampling shall be done in accordance with Practice D 4057 or D 4177 and as described in Table 3.

7.2.1.1 *Group 0*—Condition the sample container to below 5°C, preferably by filling the bottle with the cold liquid sample and discarding the first sample. If this is not possible because, for instance, the product to be sampled is at ambient temperature, the sample shall be drawn into a bottle, prechilled to below 5°C, in such a manner that agitation is kept at a minimum. Close the bottle immediately with a tight-fitting closure and place the sample in an ice bath or refrigerator.

7.2.1.2 *Group 1*—Collect the sample as described in 7.2.1.1 at a temperature below 10°C. If this is not possible because, for instance, the product to be sampled is at ambient temperature, the sample shall be drawn into a bottle prechilled to below 10°C, in such a manner that agitation is kept at a minimum. Close the bottle immediately with a tight-fitting closure. (**Warning**—Do not completely fill and tightly seal a cold bottle of sample because of the likelihood of breakage on warming.)

7.2.1.3 *Groups 2, 3, and 4*—Collect the sample at ambient temperature. After sampling, close the sample bottle immediately with a tight-fitting closure.

7.2.1.4 If the sample received by the testing laboratory has been sampled by others and it is not known whether sampling has been performed as described in 7.2, the sample shall be assumed to have been so sampled.

7.3 Sample Storage:

7.3.1 If testing is not to start immediately after collection, store the samples as indicated in 7.3.2, 7.3.3, 7.3.4, and Table 3. All samples shall be stored away from direct sunlight or sources of direct heat.

7.3.2 *Group 0*—Samples shall be stored in a refrigerator below a temperature of 5°C.

7.3.3 *Group 1*—Store the sample at a temperature below 10°C.

NOTE 8—If there are no, or inadequate, facilities for storage below 10°C, the sample may also be stored at a temperature below 20°C, provided the operator ensures that the sample container is tightly closed and leak-free.

7.3.4 *Group 2*—Store the sample at a temperature below 10°C.

NOTE 9—If there are no, or inadequate, facilities for storage below 10°C, the sample may also be stored at a temperature below 20°C, provided the operator ensures that the sample container is tightly closed and leak-free.

7.3.5 *Groups 3 and 4*—Store the sample at ambient or lower temperature.

7.4 Sample Conditioning Prior to Analysis:

7.4.1 Samples shall be conditioned to the temperature shown in Table 3 before opening the sample container.

7.4.1.1 *Group 0*—Samples shall be conditioned to a temperature of less than 5°C (40°F) before opening the sample container.

7.4.1.2 *Groups 1 and 2*—Samples shall be conditioned to a temperature of less than 10°C (50°F) before opening the sample container.

7.4.1.3 *Groups 3 and 4*—If the sample is not fluid at ambient temperature, it is to be heated to a temperature of 9 to 21°C above its pour point (Test Method D 97, D 5949, or D 5985) prior to analysis. If the sample has partially or completely solidified during storage, it shall be vigorously shaken after melting prior to opening the sample container to ensure homogeneity.

7.4.1.4 If the sample is not fluid at room temperature, the temperature ranges shown in Table 3 for the flask and for the sample do not apply.

7.5 Wet Samples:

7.5.1 Samples of materials that visibly contain water are not suitable for testing. If the sample is not dry, obtain another sample that is free from suspended water.

7.5.2 *Groups 0, 1, and 2*—If such a sample cannot be obtained, the suspended water can be removed by maintaining the sample at 0 to 10°C, adding approximately 10 g of anhydrous sodium sulfate per 100 mL of sample, shaking the mixture for approximately 2 min, and then allowing the mixture to settle for approximately 15 min. Once the sample shows no visible signs of water, use a decanted portion of the sample, maintained between 1 and 10°C, for the analysis. Note in the report that the sample has been dried by the addition of a desiccant.

NOTE 10—Suspended water in hazy samples in Groups 1 and 2 can be removed by the addition of anhydrous sodium sulfate and separating the liquid sample from the drying agent by decanting without statistically affecting the results of the test.⁸

7.5.3 *Groups 3 and 4*—In cases in which a water-free sample is not practical, the suspended water can be removed by shaking the sample with anhydrous sodium sulfate or other suitable drying agent and separating it from the drying agent by decanting. Note in the report that the sample has been dried by the addition of a desiccant.

TABLE 2 Group Characteristics

	Group 0	Group 1	Group 2	Group 3	Group 4
Sample characteristics					
Distillate type	natural gasoline				
Vapor pressure at 37.8°C, kPa	≥65.5	<65.5	<65.5	<65.5	<65.5
100°F, psi	≥9.5	<9.5	<9.5	<9.5	<9.5
(Test Methods D 323, D 4953, D 5190, D 5191, D 5482, IP 69 or IP 394)					
Distillation, IBP °C			≤100		>100
°F			≤212		>212
EP °C	≤250	≤250	>250	>250	>250
°F	≤482	≤482	>482	>482	>482

⁸ Supporting data have been filed at ASTM International Headquarters and may be obtained by requesting Research Report RR: D02-1455.

TABLE 3 Sampling, Storage, and Sample Conditioning

		Group 0	Group 1	Group 2	Group 3	Group 4
Temperature of sample bottle	°C	<5	<10			
	°F	<40	<50			
Temperature of stored sample	°C	<5	<10 ^A	<10	ambient	ambient
	°F	<40	<50 ^A	<50	ambient	ambient
Temperature of sample after conditioning prior to analysis	°C	<5	<10	<10	Ambient or 9 to 21°C above pour point ^B	Ambient or 9 to 21°C above pour point ^B
	°F	<40	<50	<50	Ambient or 48 to 70°F above pour point ^B	Ambient or 48 to 70°F above pour point ^B
If sample is wet		resample	resample	resample		
If resample is still wet ^C			dry in accordance with 7.5.2		dry in accordance with 7.5.3	

^A Under certain circumstances, samples can also be stored at temperatures below 20°C (68°F). See also 7.3.3 and 7.3.4.

^B If sample is (semi)-solid at ambient temperature, see also 10.3.1.1.

^C If sample is known to be wet, resampling may be omitted. Dry sample in accordance with 7.5.2 and 7.5.3.

8. Preparation of Apparatus

8.1 Refer to Table 1 and prepare the apparatus by choosing the appropriate distillation flask, temperature measuring device, and flask support board, as directed for the indicated group. Bring the temperature of the receiving cylinder, the flask, and the condenser bath to the indicated temperature.

8.2 Make any necessary provisions so that the temperature of the condenser bath and the receiving cylinder will be maintained at the required temperatures. The receiving cylinder shall be in a bath such that either the liquid level is at least as high as the 100-mL mark or the entire receiving cylinder is surrounded by an air circulation chamber.

8.2.1 *Groups 0, 1, 2, and 3*—Suitable media for low temperature baths include, but are not limited to, chopped ice and water, refrigerated brine, and refrigerated ethylene glycol.

8.2.2 *Group 4*—Suitable media for ambient and higher bath temperatures include, but are not limited to, cold water, hot water, and heated ethylene glycol.

8.3 Remove any residual liquid in the condenser tube by swabbing with a piece of soft, lint-free cloth attached to a cord or wire.

9. Calibration and Standardization

9.1 *Temperature Measurement System*—Temperature measurement systems using other than the specified mercury-in-glass thermometers shall exhibit the same temperature lag, emergent stem effect, and accuracy as the equivalent mercury-in-glass thermometer. Confirmation of the calibration of these temperature measuring systems shall be made at intervals of not more than six months, and after the system has been replaced or repaired.

9.1.1 The accuracy and the calibration of the electronic circuitry or computer algorithms, or both, shall be verified by the use of a standard precision resistance bench. When performing this verification, no algorithms shall be used to correct the temperature for lag and the emergent stem effect (see manufacturer's instructions).

9.1.2 The magnitude of the bias shall be verified by distilling pure toluene in accordance with this test method and comparing the 50 % recovered temperature with that shown by the above mentioned mercury-in-glass thermometers when carrying out a manual test under the same conditions.

9.1.2.1 If the temperature reading differs more than 0.2°C from the expected temperature (see Note 12 and Table 4), the

TABLE 4 True and D 86 Boiling Points of Toluene

Thermometer	ASTM IP	7C, 7F 5C		8C, 8F 6C	
Compound	true boiling point °C	D 86 boiling point °C	bias	D 86 boiling point °C	bias
Toluene	110.6	109.3	-1.3	109.9	-0.7

temperature measurement system shall be considered defective and shall not be used for the test.

NOTE 11—Toluene is used as a verification fluid for bias; it will yield almost no information on how well an electronic measurement system simulates the temperature lag of a mercury-in-glass thermometer.

9.1.2.2 Reagent grade toluene, conforming to the specifications of the Committee on Analytical Reagents of the American Chemical Society,⁹ shall be used for this test. However, other grades may also be used, provided it is first ascertained that the reagent is of sufficient purity to permit its use without lessening the accuracy of the determination.

NOTE 12—At 101.3 kPa, toluene is shown in reference manuals as boiling at 110.6°C when measured using a partial immersion thermometer. Because this test method uses thermometers calibrated for total immersion, the results will be lower and, depending on the thermometer and the situation, may be different for each thermometer. The estimated figures are 109.3°C (228.7°F) when using the low range thermometer and 109.9°C (229.8°F) when using the high range thermometer.

9.1.3 A procedure to determine the magnitude of the temperature lag is described in Annex A3.

9.1.4 A procedure to emulate the emergent stem effect is described in Appendix X4.

9.1.5 To verify the ability of the temperature measurement system to emulate mercury-in-glass thermometer at elevated temperatures, use cetane (n-hexadecane). The temperature measurement system shall indicate at, 50% distilled, a temperature of 275.3 ± 1.0°C under Group 3 distillation conditions and 278.6 ± 1.0°C under Group 4 distillation conditions.

NOTE 13—Because of the high melting point of n-hexadecane, Group 3

⁹ *Reagent Chemicals, American Chemical Society Specifications*, American Chemical Society, Washington, DC. For suggestions on the testing of reagents not listed by the American Chemical Society, see *Annual Standards for Laboratory Chemicals*, BDH Ltd., Poole, Dorset, U.K., and the *United States Pharmacopeia and National Formulary*, U.S. Pharmacopeial Convention, Inc. (USPC), Rockville, MD.

verification distillations will have to be carried out with condenser temperatures $>20^{\circ}\text{C}$.

9.2 Automated Method:

9.2.1 *Level Follower*—For an automated distillation apparatus, the level follower/recording mechanism of the apparatus shall have a resolution of 0.1 mL or better with a maximum error of 0.3 mL between the 5 and 100 mL points. The calibration of the assembly shall be verified in accordance with manufacturer's instructions at intervals of not more than three months and after the system has been replaced or repaired.

NOTE 14—The typical calibration procedure involves verifying the output with the receiver containing 5 and 100 mL of material respectively.

9.2.2 *Barometric Pressure*—At intervals of not more than six months, and after the system has been replaced or repaired, the barometric reading of the instrument shall be verified against a barometer, as described in 6.6.

10. Procedure

10.1 Record the prevailing barometric pressure.

10.2 *Groups 0, 1, and 2*—Fit a low range thermometer provided with a snug-fitting cork or stopper of silicone rubber, or equivalent polymeric material, tightly into the neck of the sample container and bring the temperature of the sample to the temperature indicated in Table 1.

10.3 *Groups 0, 1, 2, 3, and 4*—Check that the temperature of the sample is as shown in Table 1. Pour the specimen precisely to the 100-mL mark of the receiving cylinder, and transfer the contents of the receiving cylinder as completely as practical into the distillation flask, ensuring that none of the liquid flows into the vapor tube.

NOTE 15—It is important that the difference between the temperature of the specimen and the temperature of the bath around the receiving cylinder is as small as practically possible. A difference of 5°C can make a difference of 0.7 mL.

10.3.1 *Groups 3 and 4*—If the sample is not fluid at ambient temperature, it is to be heated to a temperature between 9 and 21°C above its pour point (Test Method D 97, D 5949, D 5950, or D 5985) prior to analysis. If the sample has partially or completely solidified in the intervening period, it shall be vigorously shaken after melting, and prior to sampling, to ensure homogeneity.

10.3.1.1 If the sample is not fluid at ambient temperatures, disregard the temperature range shown in Table 1 for the receiving cylinder and sample. Prior to analysis, heat the receiving cylinder to approximately the same temperature as the sample. Pour the heated specimen precisely to the 100-mL mark of the receiving cylinder, and transfer the contents of the receiving cylinder as completely as practical into the distillation flask, ensuring that none of the liquid flows into the vapor tube.

NOTE 16—Any material that evaporates during the transfer will contribute to the loss; any material that remains in the receiving cylinder will contribute to the observed recovery volume at the time of the IBP.

10.4 If the sample can be expected to demonstrate irregular boiling behavior, that is, bumping, add a few boiling chips to the specimen. The addition of a few boiling chips is acceptable for any distillation.

10.5 Fit the temperature sensor through a snug-fitting device, as described in 6.4, to mechanically center the sensor in the neck of the flask. In the case of a thermometer, the bulb is centered in the neck and the lower end of the capillary is level with the highest point on the bottom of the inner wall of the vapor tube (see Fig. 5). In the case of a thermocouple or resistance thermometer, follow the manufacturer's instructions as to placement.

NOTE 17—If vacuum grease is used on the mating surface of the centering device, use the minimum amount of grease that is practical.

10.6 Fit the flask vapor tube, provided with a snug-fitting cork or rubber stopper of silicone, or equivalent polymeric material, tightly into the condenser tube. Adjust the flask in a vertical position so that the vapor tube extends into the condenser tube for a distance from 25 to 50 mm. Raise and adjust the flask support board to fit it snugly against the bottom of the flask.

10.7 Place the receiving cylinder that was used to measure the specimen, without drying the inside of the cylinder, into its temperature-controlled bath under the lower end of the condenser tube. The end of the condenser tube shall be centered in the receiving cylinder and shall extend therein for a distance of at least 25 mm, but not below the 100-mL mark.

10.8 Initial Boiling Point:

10.8.1 *Manual Method*—To reduce evaporation loss of the distillate, cover the receiving cylinder with a piece of blotting paper, or similar material, that has been cut to fit the condenser tube snugly. If a receiver deflector is being used, start the distillation with the tip of the deflector just touching the wall of the receiving cylinder. If a receiver deflector is not used, keep the drip tip of the condenser away from the wall of the receiving cylinder. Note the start time. Observe and record the IBP to the nearest 0.5°C (1.0°F). If a receiver deflector is not being used, immediately move the receiving cylinder so that the tip of the condenser touches its inner wall.

10.8.2 *Automated Method*—To reduce evaporation loss of the distillate, use the device provided by the instrument manufacturer for this purpose. Apply heat to the distillation flask and contents with the tip of the receiver deflector just touching the wall of the receiving cylinder. Note the start time. Record the IBP to the nearest 0.1°C (0.2°F).

10.9 Regulate the heating so that the time interval between the first application of heat and the IBP is as specified in Table 5.

10.10 Regulate the heating so that the time from IBP to 5 or 10 % recovered is as indicated in Table 5.

10.11 Continue to regulate the heating so that the uniform average rate of condensation from 5 or 10 % recovered to 5 mL residue in the flask is 4 to 5 mL per min. (**Warning**—Due to the configuration of the boiling flask and the conditions of the test, the vapor and liquid around the temperature sensor are not in thermodynamic equilibrium. The distillation rate will consequently have an effect on the measured vapor temperature. The distillation rate shall, therefore, be kept as constant as possible throughout the test.)

NOTE 18—When testing gasoline samples, it is not uncommon to see the condensate suddenly form non-miscible liquid phases and bead up on the temperature measuring device and in the neck of the boiling flask at a

TABLE 5 Conditions During Test Procedure

	Group 0	Group 1	Group 2	Group 3	Group 4
Temperature of cooling bath ^A					
°C	0–1	0–1	0–5	0–5	0–60
°F	32–34	32–34	32–40	32–40	32–140
Temperature of bath around receiving cylinder					
°C	0–4	13–18	13–18	13–18	±3
°F	32–40	55–65	55–65	55–65	±5
					of charge temperature
Time from first application of heat to initial boiling point, min	2–5	5–10	5–10	5–10	5–15
Time from initial boiling point to 5 % recovered, s		60–100	60–100		
to 10 % recovered, min	3–4				
Uniform average rate of condensation from 5 % recovered to 5 mL in flask, mL/min	4–5	4–5	4–5	4–5	4–5
Time recorded from 5 mL residue to end point, min	5 max	5 max	5 max	5 max	5 max

^A the proper condenser bath temperature will depend upon the wax content of the sample and of its distillation fractions. The test is generally performed using one single condenser temperature. Wax formation in the condenser can be deduced from (a) the presence of wax particles in the distillate coming off the drip tip, (b) a higher distillation loss than what would be expected based on the initial boiling point of the specimen, (c) an erratic recovery rate and (d) the presence of wax particles during the removal of residual liquid by swabbing with a lint-free cloth (see 8.3). The minimum temperature that permits satisfactory operation shall be used. In general, a bath temperature in the 0 to 4°C range is suitable for kerosene, Grade No. 1 fuel oil and Grade No. 1-D diesel fuel oil. In some cases involving Grade No. 2 fuel oil, Grade No. 2-D diesel fuel oil, gas oils and similar distillates, it may be necessary to hold the condenser bath temperature in the 38 to 60°C range.

vapor temperature of around 160°C. This may be accompanied by a sharp (about 3°C) dip in the vapor temperature and a drop in the recovery rate. The phenomenon, which may be due to the presence of trace water in the sample, may last for 10 to 30 s before the temperature recovers and the condensate starts flowing smoothly again. This point is sometimes colloquially referred to as the Hesitation Point.

10.12 Repeat any distillation that did not meet the requirements described in 10.9, 10.10, and 10.11.

10.13 If a decomposition point, as described in 3.1.2.1, is observed, discontinue the heating and proceed as directed in 10.17.

10.14 In the interval between the IBP and the end of the distillation, observe and record data necessary for the calculation and reporting of the results of the test as required by the specification involved, or as previously established for the sample under test. These observed data can include temperature readings at prescribed percentages recovered or percentages recovered at prescribed temperature readings, or both.

10.14.1 *Manual Method*—Record all volumes in the graduated cylinder to the nearest 0.5 mL, and all temperature readings to the nearest 0.5°C (1.0°F).

10.14.2 *Automated Method*—Record all volumes in the receiving cylinder to the nearest 0.1 mL, and all temperature readings to the nearest 0.1°C (0.2°F).

10.14.3 *Group 0*—In cases in which no specific data requirements have been indicated, record the IBP, the EP (FBP), and temperature readings at each 10 % multiple of volume recovered from 10 to 90, inclusive.

10.14.4 *Group 1, 2, 3, and 4*—In cases in which no specific data requirements have been indicated, record the IBP and the EP (FBP) or the dry point, or both, and temperature readings at 5, 15, 85, and 95 % recovered, and at each 10 % multiple of volume recovered from 10 to 90, inclusive.

10.14.4.1 *Group 4*—When a high range thermometer is used in testing aviation turbine fuels and similar products, pertinent thermometer readings can be obscured by the centering device. If these readings are required, perform a second distillation in accordance with Group 3. In such cases, reading

from a low range thermometer can be reported in place of the obscured high range thermometer readings, and the test report shall so indicate. If, by agreement, the obscured readings are waived, the test report shall so indicate.

10.14.5 When it is required to report the temperature reading at a prescribed percent evaporated or recovered for a sample that has a rapidly changing slope of the distillation curve in the region of the prescribed percent evaporated or recovered reading, record temperature readings at every 1 % recovered. The slope is considered rapidly changing if the change in slope (*C*) of the data points described in 10.14.2 in that particular area is greater than 0.6 (change of slope (*F*) is greater than 1.0) as calculated by Eq 1 (Eq 2).

$$\text{Change of Slope } (C) = \frac{(C_2 - C_1)/(V_2 - V_1) - (C_3 - C_2)/(V_3 - V_2)}{\quad} \quad (1)$$

$$\text{Change of Slope } (F) = \frac{(F_2 - F_1)/(V_2 - V_1) - (F_3 - F_2)/(V_3 - V_2)}{\quad} \quad (2)$$

where:

C_1 = temperature at the volume % recorded one reading prior to the volume % in question, °C,

C_2 = temperature at the volume % recorded in question, °C,

C_3 = temperature at the volume % recorded following the volume % in question, °C,

F_1 = temperature at the volume % recorded one reading prior to the volume % in question, °F,

F_2 = temperature at the volume % recorded in question, °F,

F_3 = temperature at the volume % recorded following the volume % in question, °F,

V_1 = volume % recorded one reading prior to the volume % in question,

V_2 = volume % recorded at the volume % in question, and

V_3 = volume % recorded following the volume % in question.

10.15 When the residual liquid in the flask is approximately 5 mL, make a final adjustment of the heat. The time from the 5 mL of liquid residue in the flask to the EP (FBP) shall be within the limits prescribed in Table 5. If this condition is not satisfied, repeat the test with appropriate modification of the final heat adjustment.

NOTE 19—Since it is difficult to determine when there is 5 mL of boiling liquid left in the flask, this time is determined by observing the amount of liquid recovered in the receiving cylinder. The dynamic holdup has been determined to be approximately 1.5 mL at this point. If there are no front end losses, the amount of 5 mL in the flask can be assumed to correspond with an amount of 93.5 mL in the receiving cylinder. This amount has to be adjusted for the estimated amount of front end loss.

10.15.1 If the actual front end loss differs more than 2 mL from the estimated value, the test shall be rerun.

10.16 Observe and record the EP (FBP) or the dry point, or both, as required, and discontinue the heating.

10.17 Allow the distillate to drain into the receiving cylinder, after heating has been discontinued.

10.17.1 *Manual Method*—While the condenser tube continues to drain into the graduated cylinder, observe and note the volume of condensate to the nearest 0.5 mL at 2 min intervals until two successive observations agree. Measure the volume in the receiving cylinder accurately, and record it to the nearest 0.5 mL.

10.17.2 *Automated Method*—The apparatus shall continually monitor the recovered volume until this volume changes by no more than 0.1 mL in 2 min. Record the volume in the receiving cylinder accurately to the nearest 0.1 mL.

10.18 Record the volume in the receiving cylinder as percent recovery. If the distillation was previously discontinued under the conditions of a decomposition point, deduct the percent recovered from 100, report this difference as the sum of percent residue and percent loss, and omit the procedure given in 10.19.

10.19 After the flask has cooled and no more vapor is observed, disconnect the flask from the condenser, pour its contents into a 5-mL graduated cylinder, and with the flask suspended over the cylinder, allow the flask to drain until no appreciable increase in the volume of liquid in the cylinder is observed. Measure the volume in the graduated cylinder to the nearest 0.1 mL, and record as percent residue.

10.19.1 If the 5-mL graduated cylinder does not have graduations below 1 mL and the volume of liquid is less than 1 mL, prefill the cylinder with 1 mL of a heavy oil to allow a better estimate of the volume of the material recovered.

10.19.1.1 If a residue larger than 5 mL is obtained and the distillation was not purposely terminated before the EP, check whether adequate heat was applied towards the end of the distillation and whether conditions during the test conform to those specified in Table 5 (**Warning**—Take adequate precautions when removing the hot flask to prevent accidental burns.)

NOTE 20—The test method is not designed for the analysis of distillate fuels containing appreciable quantities of residual material (see 1.2).

10.19.2 *Group 0*—Cool the 5-mL graduated cylinder to below 5°C. Record the volume in the graduated cylinder, to the nearest 0.1 mL, as percent residue.

10.19.3 *Groups 1, 2, 3, and 4*—Record the volume in the 5-mL graduated cylinder, to the nearest 0.1 mL, as percent residue.

10.20 If the intent of the distillation is to determine the percent evaporated or percent recovered at a predetermined corrected temperature reading, modify the procedure to conform to the instructions described in Annex A4.

10.21 Examine the condenser tube and the side arm of the flask for waxy or solid deposits. If found, repeat the test after making adjustments described in Footnote A of Table 5.

11. Calculations

11.1 The percent total recovery is the sum of the percent recovery (see 10.18) and the percent residue (see 10.19). Deduct the percent total recovery from 100 to obtain the percent loss.

11.2 Do not correct the barometric pressure for meniscus depression, and do not adjust the pressure to what it would be at sea level.

NOTE 21—The observed barometric reading does not have to be corrected to a standard temperature and to standard gravity. Even without performing these corrections, the corrected temperature readings for the same sample between laboratories at two different locations in the world will, in general, differ less than 0.1°C at 100°C. Almost all data obtained earlier have been reported at barometric pressures that have not been corrected to standard temperature and to standard gravity.

11.3 Correct temperature readings to 101.3 kPa (760 mm Hg) pressure. Obtain the correction to be applied to each temperature reading by means of the Sydney Young equation as given in Eq 3, Eq 4, or Eq 5, as appropriate, or by the use of Table 6. For Celsius temperatures:

$$C_c = 0.0009 (101.3 - P_k) (273 + t_c) \quad (3)$$

$$C_c = 0.00012 (760 - P) (273 + t_c) \quad (4)$$

For Fahrenheit temperatures:

TABLE 6 Approximate Thermometer Reading Correction

Temperature Range		Correction ^A per 1.3 kPa (10 mm Hg) Difference in Pressure	
°C	°F	°C	°F
10–30	50–86	0.35	0.63
30–50	86–122	0.38	0.68
50–70	122–158	0.40	0.72
70–90	158–194	0.42	0.76
90–110	194–230	0.45	0.81
110–130	230–266	0.47	0.85
130–150	266–302	0.50	0.89
150–170	302–338	0.52	0.94
170–190	338–374	0.54	0.98
190–210	374–410	0.57	1.02
210–230	410–446	0.59	1.07
230–250	446–482	0.62	1.11
250–270	482–518	0.64	1.15
270–290	518–554	0.66	1.20
290–310	554–590	0.69	1.24
310–330	590–626	0.71	1.28
330–350	626–662	0.74	1.33
350–370	662–698	0.76	1.37
370–390	698–734	0.78	1.41
390–410	734–770	0.81	1.46

^A Values to be added when barometric pressure is below 101.3 kPa (760 mm Hg) and to be subtracted when barometric pressure is above 101.3 kPa.

$$C_f = 0.00012 (760 - P) (460 + t_f) \quad (5)$$

where:

- t_c = the observed temperature reading in °C,
- t_f = the observed temperature reading in °F,
- C_c and C_f = corrections to be added algebraically to the observed temperature readings,
- P_k = barometric pressure, prevailing at the time and location of the test, kPa, and
- P = barometric pressure, prevailing at the time and location of the test, mm Hg.

After applying the corrections and rounding each result to the nearest 0.5°C (1.0°F) or 0.1°C (0.2°F), as appropriate to the apparatus being used, use the corrected temperature readings in all further calculations and reporting.

NOTE 22—Temperature readings are not corrected to 101.3 kPa (760 mm Hg) when product definitions, specifications, or agreements between the parties involved indicate, specifically, that such correction is not required or that correction shall be made to some other base pressure.

11.4 Correct the actual loss to 101.3 kPa (760 mm Hg) pressure when temperature readings are corrected to 101.3 kPa pressure. The corrected loss, L_c , is calculated from Eq 6 or Eq 7, as appropriate, or can be read from the tables presented as Fig. X3.1 or Fig. X3.2.

$$L_c = 0.5 + (L - 0.5) / \{1 + (101.3 - P_k) / 8.00\} \quad (6)$$

$$L_c = 0.5 + (L - 0.5) / \{1 + (760 - P) / 60.0\} \quad (7)$$

where:

- L = observed loss,
- L_c = corrected loss,
- P_k = pressure, kPa, and
- P = pressure, mm Hg.

NOTE 23—Eq 6 and 7 above have been derived from the data in Table 7 and Eqs 5 and 6 in Test Method D 86 – 95 and earlier versions. It is probable that Eq 6 and 7 shown were the original empirical equations from which the table and equations in the Test Method D 86 – 95 and earlier versions were derived.

11.4.1 Calculate the corresponding corrected percent recovery in accordance with the following equation:

$$R_c = R + (L - L_c) \quad (8)$$

where:

- L = percent loss or observed loss,
- L_c = corrected loss,
- R = percent recovery, and
- R_c = corrected percent recovery.

11.5 To obtain the percent evaporated at a prescribed temperature reading, add the percent loss to each of the

observed percent recovered at the prescribed temperature readings, and report these results as the respective percent evaporated, that is:

$$P_e = P_r + L \quad (9)$$

where:

- L = observed loss,
- P_e = percent evaporated, and
- P_r = percent recovered.

11.6 To obtain temperature readings at prescribed percent evaporated, and if no recorded temperature data is available within 0.1 volume % of the prescribed percent evaporated, use either of the two following procedures, and indicate on the report whether the arithmetical procedure or the graphical procedure has been used.

11.6.1 *Arithmetical Procedure*—Deduct the observed loss from each prescribed percent evaporated to obtain the corresponding percent recovered. Calculate each required temperature reading as follows:

$$T = T_L + (T_H - T_L) (R - R_L) / (R_H - R_L) \quad (10)$$

where:

- R = percent recovered corresponding to the prescribed percent evaporated,
- R_H = percent recovered adjacent to, and higher than R ,
- R_L = percent recovered adjacent to, and lower than R ,
- T = temperature reading at the prescribed percent evaporated,
- T_H = temperature reading recorded at R_H , and
- T_L = temperature reading recorded at R_L .

Values obtained by the arithmetical procedure are affected by the extent to which the distillation graphs are nonlinear. Intervals between successive data points can, at any stage of the test, be no wider than the intervals indicated in 10.14. In no case shall a calculation be made that involves extrapolation.

11.6.2 *Graphical Procedure*—Using graph paper with uniform subdivisions, plot each temperature reading corrected for barometric pressure, if required (see 11.3), against its corresponding percent recovered. Plot the IBP at 0 % recovered. Draw a smooth curve connecting the points. For each prescribed percent evaporated, deduct the distillation loss to obtain the corresponding percent recovered and take from the graph the temperature reading that this percent recovered indicates. Values obtained by graphical interpolation procedures are affected by the care with which the plot is made.

NOTE 24—See Appendix X1 for numerical examples illustrating the arithmetical procedure.

11.6.3 In most automated instruments, temperature-volume data are collected at 0.1 volume % intervals or less and stored

TABLE 7 Data Points for Determining Slope, S_C or S_F

Slope at %	IBP	5	10	20	30	40	50	60	70	80	90	95	EP
T_L at %	0	0	0	10	20	30	40	50	60	70	80	90	95
T_U at %	5	10	20	30	40	50	60	70	80	90	95	95	V_{EP}
$V_U - V_L$	5	10	20	20	20	20	20	20	20	20	10	5	V_{EP-95}

in memory. To report a temperature reading at a prescribed percent evaporated, neither of the procedures described in 11.6.1 and 11.6.2 have to be used. Obtain the desired temperature directly from the database as the temperature closest to and within 0.1 volume % of the prescribed percent evaporated.

12. Report

12.1 Report the following information:

12.2 Report the barometric pressure to the nearest 0.1 kPa (1 mm Hg).

12.3 Report all volumetric readings in percentages.

12.3.1 *Manual Method*—Report volumetric readings to the nearest 0.5, and all temperature readings to the nearest 0.5°C (1.0°F).

12.3.2 *Automated Method*—Report volumetric readings to the nearest 0.1, and all temperature readings to the nearest 0.1°C (0.2°F) or less.

12.4 After barometric corrections of the temperature readings have been made, the following data require no further calculation prior to reporting: IBP, dry point, EP (FBP), decomposition point, and all pairs of corresponding values involving percent recovered and temperature readings.

12.4.1 The report shall state if the temperature readings have not been corrected for barometric pressure.

12.5 When the temperature readings have not been corrected to 101.3 kPa (760 mm Hg) pressure, report the percent residue and percent loss as *observed* in accordance with 10.19 and 11.1, respectively.

12.6 Do not use the corrected loss in the calculation of percent evaporated.

12.7 It is advisable to base the report on relationships between temperature readings and percent evaporated when the sample is a gasoline, or any other product classified under Group 0 or 1, or in which the percent loss is greater than 2.0. Otherwise, the report can be based on relationships between temperature readings and percent evaporated or percent recovered. Every report must indicate clearly which basis has been used.

12.7.1 In the manual method, if results are given in percent evaporated versus temperature readings, report if the arithmetical or the graphical procedure was used (see 11.6).

12.8 Report if a drying agent, as described in 7.5.2 or 7.5.3, was used.

12.9 Figure X1.1 is an example of a tabular report. It shows the percent recovered versus the corresponding temperature reading and versus the corrected temperature reading. It also shows the percent loss, the corrected loss, and the percent evaporated versus the corrected temperature reading.

13. Precision and Bias

13.1 *Precision:*

13.1.1 The precision of this test method has been determined by the statistical examination of interlaboratory test results obtained by 26 laboratories on 14 gasolines, by 4 laboratories on 8 samples of kerosene by the manual procedure, 3 laboratories on 6 samples of kerosene by the automated procedure, and 5 laboratories on 10 samples of diesel fuel by both the manual and automated procedures. Table A1.1 lists

which tables and figures are to be used for the different fuel groups, distillation methods, and temperature scales.

13.1.2 The following terms are used in this section: (1) *r* = repeatability and (2) *R* = reproducibility. The value of any of these terms will depend upon whether the calculations were carried out in °C or °F.

13.2 *Slope or Rate of Change of Temperature:*

13.2.1 To determine the precision of a result, it is generally necessary to determine the slope or rate of change of the temperature at that particular point. This variable, denoted as S_C or S_F , is equal to the change in temperature, either in °C or in °F, respectively, per percent recovered or evaporated.

13.2.2 For Group 1 in the manual method and for all groups in the automated method, the precision of the IBP and EP does not require any slope calculation.

13.2.3 With the exception stated in 13.2.2 and in 13.2.4, the slope at any point during the distillation is calculated from the following equations, using the values shown in Table 7:

$$S_C \text{ (or } S_F) = (T_U - T_L) / (V_U - V_L) \quad (11)$$

where:

S_C = is the slope, °C/volume %,

S_F = is the slope, °F/volume %,

T_U = is the upper temperature, °C (or °F),

T_L = is the lower temperature, °C (or °F),

V_U = is the volume % recovered or evaporated corresponding to T_U ,

V_L = is the volume % recovered or evaporated corresponding to T_L , and

V_{EP} = is the volume % recovered or evaporated corresponding to the end point.

13.2.4 In the event that the distillation end point occurs prior to the 95 % point, the slope at the end point is calculated as follows:

$$S_C \text{ (or } S_F) = (T_{EP} - T_{HR}) / (V_{EP} - V_{HR}) \quad (12)$$

where:

T_{EP} or T_{HR} is the temperature, in °C or °F at the percent volume recovered indicated by the subscript,

V_{EP} or V_{HR} is the volume % recovered.

13.2.4.1 The subscripts in Eq 12 refer to:

EP = end point

HR = highest reading, either 80 % or 90 %, prior to the end point.

13.2.5 For points between 10 to 85 % recovered which are not shown in Table 7, the slope is calculated as follows:

$$S_C \text{ (or } S_F) = 0.05 (T_{(V+10)} - T_{(V-10)}) \quad (13)$$

13.2.6 For samples in Group 1, the precision data reported are based on slope values calculated from percent evaporated data.

13.2.7 For samples in Group 2, 3, and 4, the precision data reported (Table 8) are based on slope values calculated from percent recovered data.

13.2.8 When results are reported as volume % recovered, slope values for the calculation of precision are to be determined from percent recovered data; when results are reported

TABLE 8 Repeatability and Reproducibility for Group 1

Evaporated Point, %	Manual Repeatability ^A		Manual Reproducibility ^A		Automated Repeatability ^A		Automated Reproducibility ^A	
	°C	°F	°C	°F	°C	°F	°C	°F
	IBP	3.3	6	5.6	10	3.9	7	7.2
5	1.9+0.86S _C	3.4+0.86S _F	3.1+1.74S _C	5.6+1.74S _F	2.1+0.67S _C	3.8+0.67S _F	4.4+2.0S _C	7.9+2.0S _F
10	1.2+0.86S _C	2.2+0.86S _F	2.0+1.74S _C	3.6+1.74S _F	1.7+0.67S _C	3.0+0.67S _F	3.3+2.0S _C	6.0+2.0S _F
20	1.2+0.86S _C	2.2+0.86S _F	2.0+1.74S _C	3.6+1.74S _F	1.1+0.67S _C	2.0+0.67S _F	3.3+2.0S _C	6.0+2.0S _F
30–70	1.2+0.86S _C	2.2+0.86S _F	2.0+1.74S _C	3.6+1.74S _F	1.1+0.67S _C	2.0+0.67S _F	2.6+2.0S _C	4.7+2.0S _F
80	1.2+0.86S _C	2.2+0.86S _F	2.0+1.74S _C	3.6+1.74S _F	1.1+0.67S _C	2.0+0.67S _F	1.7+2.0S _C	3.0+2.0S _F
90	1.2+0.86S _C	2.2+0.86S _F	0.8+1.74S _C	1.4+1.74S _F	1.1+0.67S _C	2.0+0.67S _F	0.7+2.0S _C	1.2+2.0S _F
95	1.2+0.86S _C	2.2+0.86S _F	1.1+1.74S _C	1.9+1.74S _F	2.5+0.67S _C	4.5+0.67S _F	2.6+2.0S _C	4.7+2.0S _F
FBP	3.9	7	7.2	13	4.4	8	8.9	16

^A S_C or S_F is the average slope (or rate of change) calculated in accordance with 13.2.

TABLE 9 Repeatability and Reproducibility for Groups 2, 3 and 4 (Manual Method)

	Repeatability ^A		Reproducibility ^A	
	°C	°F	°C	°F
	IBP	1.0+0.35S _C	1.9+0.35S _F	2.8+0.93S _C
5–95 %	1.0+0.41S _C	1.8+0.41S _F	1.8+1.33S _C	3.3+1.33S _F
FBP	0.7+0.36S _C	1.3+0.36S _F	3.1+0.42S _C	5.7+0.42S _F
% volume at temperature reading	0.7+0.92/S _C	0.7+1.66/S _F	1.5+1.78/S _C	1.53+3.20/S _F

^A Calculate S_C or S_F from 13.2.

as volume % evaporated slope values are to be determined from % evaporated data.

13.3 Manual Method:

13.3.1 Repeatability:

13.3.1.1 *GROUP 0*—Duplicate results obtained for the EP shall not differ from each other by more than 3.5°C (6°F) in one case in twenty. Differences in duplicate temperature readings for each prescribed percentage point shall not exceed the amounts equivalent to 2 mL of distillate at each point in question. The calculation of this maximum difference is described in Annex A5.

13.3.1.2 *GROUP 1*—The difference between successive results obtained by the same operator with the same apparatus under constant operating conditions on identical test material would, in the long run, in the normal and correct operation of this test method, exceed the values calculated from Table 9 in only one case in twenty.

13.3.1.3 *GROUPS 2, 3, and 4*—The difference between successive results obtained by the same operator with the same apparatus under constant operating conditions on identical test material would, in the long run, in the normal and correct operation of this test method, exceed the values calculated from the values in Table 9 in only one case in twenty.

13.3.2 Reproducibility:

13.3.2.1 *GROUP 0*—The reproducibility of the test method for this group has not been determined.

13.3.2.2 *GROUP 1*—The difference between two single and independent results obtained by different operators working in different laboratories on identical test material would, in the normal and correct operation of this method, exceed the values calculated from Table 9 in only one case in twenty.¹⁰

13.3.2.3 *GROUPS 2, 3, and 4*—The difference between two single and independent results obtained by different operators working in different laboratories on identical test material would, in the normal and correct operation of this test method, exceed the values calculated from the data in Table 9 in only one case in twenty.¹¹

13.4 Automated Method:

13.4.1 Repeatability:

13.4.1.1 *GROUP 0*—Duplicate results obtained for the endpoint shall not differ from each other by more than 3.5°C (6°F) in one case in twenty. Differences in duplicate temperature readings for each prescribed percentage point shall not exceed the amounts equivalent to 2 mL of distillate at each point in question. The calculation of this maximum difference is described in Annex A5.

13.4.1.2 *GROUP 1*—The difference between successive results obtained by the same operator with the same apparatus under constant operating conditions on identical test material would, in the long run, in the normal and correct operation of this test method, exceed the values calculated from Table 8 in only one case in twenty.

13.4.1.3 *GROUPS 2, 3, and 4*—The difference between successive results obtained by the same operator with the same apparatus under constant operating conditions on identical test material would, in the long run, in the normal and correct operation of this test method, exceed the values calculated from Table 10 in only one case in twenty.

13.4.2 Reproducibility:

13.4.2.1 *GROUP 0*—The reproducibility of the test method for this group has not been determined.

¹⁰ Precision data obtained from RR study on both manual and automated D 86 units by North American and IP Laboratories.

¹¹ Table 9 has been derived from the nomographs in Figs. 6 and 7 in ASTM D 86–97.

TABLE 10 Repeatability and Reproducibility for Groups 2, 3 and 4 (Automated)

Collected, %	Repeatability ^A		Reproducibility ^A	
	°C	°F	°C	°F
IBP	3.5	6.3	8.5	15.3
2 %	3.5	6.3	2.6 + 1.92S _C	4.7 + 1.92S _F
5 %	1.1 + 1.08S _C	2.0 + 1.08S _F	2.0 + 2.53S _C	3.6 + 2.53S _F
10 %	1.2 + 1.42S _C	2.2 + 1.42S _F	3.0 + 2.64S _C	5.4 + 2.64S _F
20–70 %	1.2 + 1.42S _C	2.2 + 1.42S _F	2.9 + 3.97S _C	5.2 + 3.97S _F
80 %	1.2 + 1.42S _C	2.2 + 1.42S _F	3.0 + 2.64S _C	5.4 + 2.64S _F
90–95 %	1.1 + 1.08S _C	2.0 + 1.08S _F	2.0 + 2.53S _C	3.6 + 2.53S _F
FBP	3.5	6.3	10.5	18.9

^A S_C or S_F is the average slope (or rate of change) calculated in accordance with 13.5.

13.4.2.2 *GROUP 1*—The difference between two single and independent results obtained by different operators working in different laboratories on identical test material would, in the normal and correct operation of this test method, exceed the values calculated from Table 8 in only one case in twenty.¹⁰

13.4.2.3 *GROUPS 2, 3, and 4*—The difference between two single and independent results obtained by different operators working in different laboratories on identical test material would, in the normal and correct operation of this test method, exceed the values calculated from Table 10 in only one case in twenty.

13.5 Bias:

13.5.1 *Relative Bias*—There exists a bias between the empirical results of distillation properties obtained by this test method and the true boiling point distillation curve obtained by

Test Method D 2892. The magnitude of this bias, and how it relates to test precision, has not been rigorously studied.

13.5.2 *Bias*—Due to the use of total immersion thermometers, or temperature sensing systems designed to emulate them, the distillation temperatures in this test method are somewhat lower than the true temperatures. The amount of bias depends on the product being distilled and the thermometer used. The bias due to the emergent stem has been determined for toluene and is shown in Table 4.

14. Keywords

14.1 batch distillation; distillates; distillation; laboratory distillation; petroleum products

ANNEXES
(Mandatory Information)
A1. REPEATABILITY AND REPRODUCIBILITY DEFINITION AIDS

A1.1 Table A1.1 is an aid for determining which repeatability and reproducibility table or section, is to be used.

TABLE A1.1 Summary of Aids for Definition of Repeatability and Reproducibility

Group	Method	Temperature Scale	Table or Section to Use	
			Repeatability	Reproducibility
0	Manual	°C or °F	13.3.1.1	13.3.2.1
	Automated	°C or °F	13.4.1.1	13.4.2.1
1	Manual	°C	Table 8	Table 8
		°F	Table 8	Table 8
1	Automated	°C	Table 8	Table 8
		°F	Table 8	Table 8
2,3,4	Manual	°C	Table 9	Table 9
		°F	Table 9	Table 9
2,3,4	Automated	°C	Table 10	Table 10
		°F	Table 10	Table 10

A2. DETAILED DESCRIPTION OF APPARATUS

A2.1 *Distillation Flasks*—Flasks shall be of heat resistant glass, constructed to the dimensions and tolerances shown in Fig. A2.1 and shall otherwise comply with the requirements of Specification E 1405. Flask A (100 mL) may also be constructed with a ground glass joint, in which case the diameter of the neck shall be the same as the 125-mL flask.

NOTE A2.1—For tests specifying dry point, specially selected flasks with bottoms and walls of uniform thickness are desirable.

A2.2 *Condenser and Condenser Bath*—Typical types of condenser and condenser baths are illustrated in Figs. 1 and 2.

A2.2.1 The condenser shall be made of seamless noncorrosive metal tubing, 560 ± 5 mm in length, with an outside diameter of 14 mm and a wall thickness of 0.8 to 0.9 mm.

NOTE A2.2—Brass or stainless steel has been found to be a suitable material for this purpose.

A2.2.2 The condenser shall be set so that 393 ± 3 mm of the tube is in contact with the cooling medium, with 50 ± 3 mm outside the cooling bath at the upper end, and with 114 ± 3 mm outside at the lower end. The portion of the tube projecting at the upper end shall be set at an angle of $75 \pm 3^\circ$ with the vertical. The portion of the tube inside the condenser bath shall be either straight or bent in any suitable continuous smooth curve. The average gradient shall be $15 \pm 1^\circ$ with respect to the horizontal, with no 10-cm section having a gradient outside of the $15 \pm 3^\circ$ range. The projecting lower portion of the condenser tube shall be curved downward for a length of 76 mm and the lower end shall be cut off at an acute angle. Provisions shall be made to enable the flow of the distillate to

run down the side of the receiving cylinder. This can be accomplished by using a drip-deflector, which is attached to the outlet of the tube. Alternatively, the lower portion of the condenser tube can be curved slightly backward to ensure contact with the wall of the receiving cylinder at a point 25 to 32 mm below the top of the receiving cylinder. Fig. A2.2 is a drawing of an acceptable configuration of the lower end of the condenser tube.

A2.2.3 The volume and the design of the bath will depend on the cooling medium employed. The cooling capacity of the bath shall be adequate to maintain the required temperature for the desired condenser performance. A single condenser bath may be used for several condenser tubes.

A2.3 *Metal Shield or Enclosure for Flask.* (Manual units only).

A2.3.1 *Shield for Gas Burner* (see Fig. 1)—The purpose of this shield is to provide protection for the operator and yet allow easy access to the burner and to the distillation flask during operation. A typical shield would be 480-mm high, 280-mm long and 200-mm wide, made of sheet metal of 0.8-mm thickness (22 gage). The shield shall be provided with at least one window to observe the dry point at the end of the distillation.

A2.3.2 *Shield for Electric Heater* (see Fig. 2)—A typical shield would be 440-mm high, 200-mm long, and 200-mm wide, made of sheet metal of approximately 0.8-mm thickness (22 gage) and with a window in the front side. The shield shall be provided with at least one window to observe the dry point at the end of the distillation.

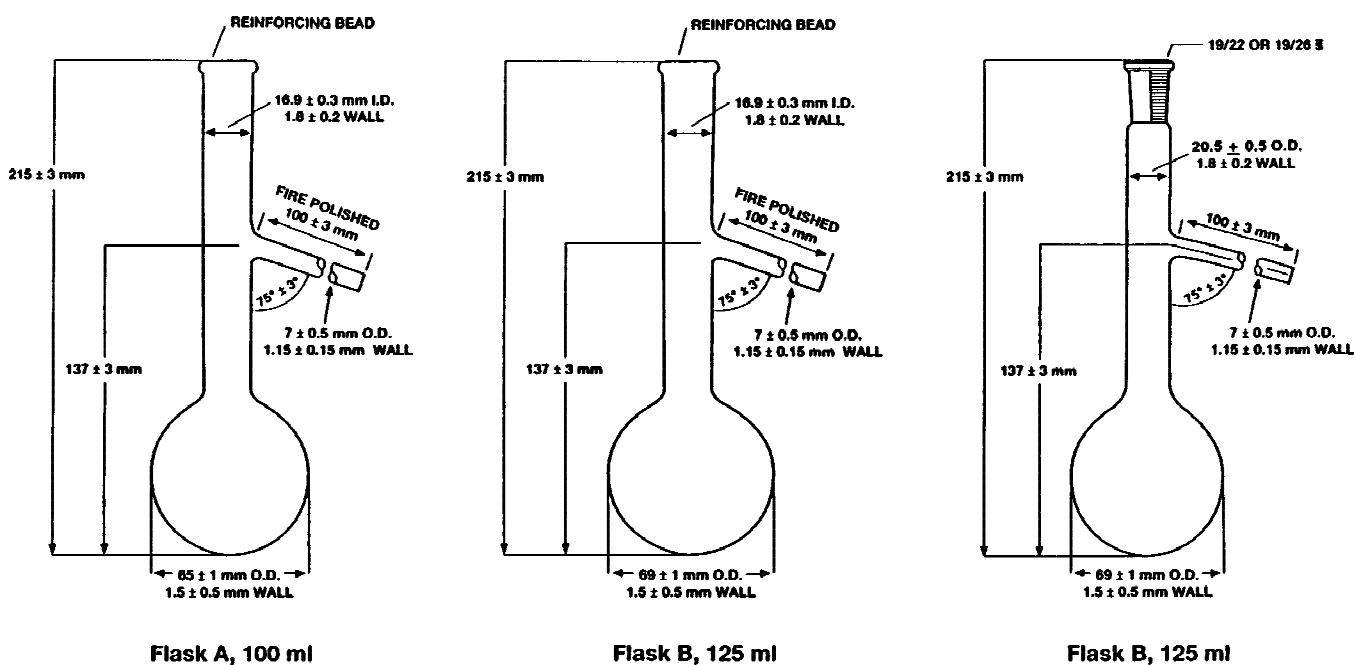
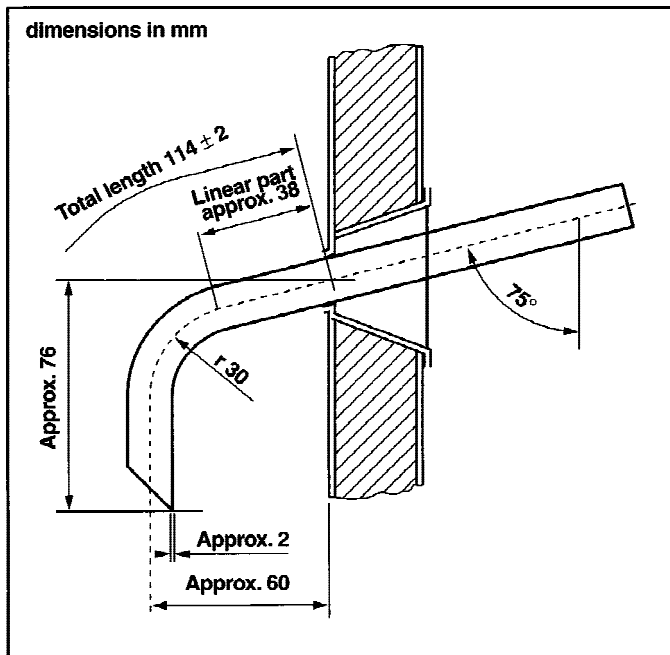

FIG. A2.1 Flask A, 100 mL, Flask B, 125 mL, and Flask B with Ground Glass Joint, 125 mL



Lower End of Condenser Tube
FIG. A2.2 Lower End of Condenser Tube

A2.4 Heat Source:

A2.4.1 Gas Burner (see Fig. 1), capable of bringing over the first drop from a cold start within the time specified and of continuing the distillation at the specified rate. A sensitive manual control valve and gas pressure regulator to give complete control of heating shall be provided.

A2.4.2 Electric Heater (see Fig. 2), of low heat retention.

NOTE A2.3—Heaters, adjustable from 0 to 1000 W, have been found to be suitable for this purpose.

A2.5 Flask Support:

A2.5.1 Type 1—Use a Type 1 flask support with a gas burner (see Fig. 1). This support consists of either a ring support of the ordinary laboratory type, 100 mm or larger in diameter, supported on a stand inside the shield, or a platform adjustable from the outside of the shield. On this ring or platform is mounted a hard board made of ceramic or other heat-resistant material, 3 to 6 mm in thickness, with a central opening 76 to 100 mm in diameter, and outside line dimensions slightly smaller than the inside boundaries of the shield.

A2.5.2 Type 2—Use a Type 2 flask support assembly with electric heating (see Fig. 2 as one example). The assembly consists of an adjustable system onto which the electric heater is mounted with provision for placement of a flask support board (see A2.6) above the electric heater. The whole assembly is adjustable from the outside of the shield.

A2.6 Flask Support Board—The flask support board shall be constructed of ceramic or other heat-resistant material, 3 to 6 mm in thickness. Flask support boards are classified as A, B, or C, based on the size of the centrally located opening, the dimension of which is shown in Table 1. The flask support board shall be of sufficient dimension to ensure that thermal

heat to the flask only comes from the central opening and that extraneous heat to the flask other than through the central opening is minimized. (**Warning**—Asbestos-containing materials shall not be used in the construction of the flask support board.)

A2.7 The flask support board can be moved slightly in different directions on the horizontal plane to position the distillation flask so that direct heat is applied to the flask only through the opening in this board. Usually, the position of the flask is set by adjusting the length of the side-arm inserted into the condenser.

A2.8 Provision shall be made for moving the flask support assembly vertically so that the flask support board is in direct contact with the bottom of the distillation flask during the distillation. The assembly is moved down to allow for easy mounting and removal of the distillation flask from the unit.

A2.9 Receiving Cylinders—The receiving cylinder shall have a capacity to measure and collect 100 mL. The shape of the base shall be such that the receiver does not topple when placed empty on a surface inclined at an angle of 13° from the horizontal.

A2.9.1 Manual Method—The cylinder shall be graduated at intervals of 1 mL and have a graduation at the 100-mL mark. Construction details and tolerances for the graduated cylinder are shown in Fig. A2.3.

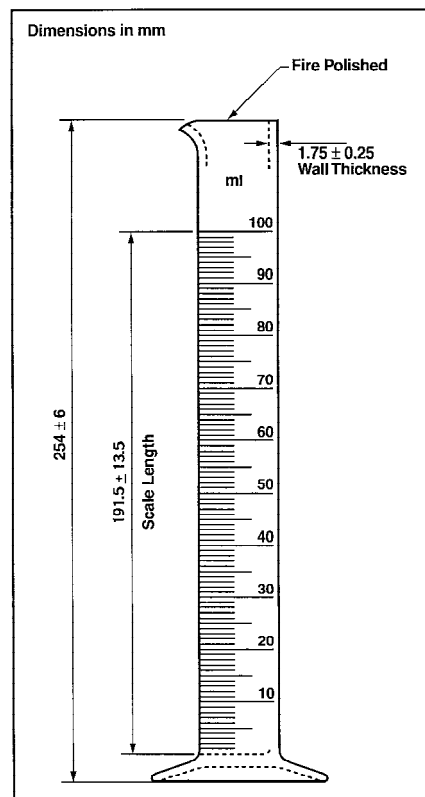

NOTE—1 to 100 mL in 1 mL graduations; tolerance ± 1.0 mL.
FIG. A2.3 100 mL Graduated Cylinder

A2.9.2 *Automated Method*—The cylinder shall conform to the physical specifications described in Fig. A2.3, except that graduations below the 100-mL mark are permitted, as long as they do not interfere with the operation of the level follower. Receiving cylinders for use in automated units may also have a metal base.

A2.9.3 If required, the receiving cylinder shall be immersed during the distillation to above the 100-mL graduation line in a cooling liquid contained in a cooling bath, such as a tall-form

beaker of clear glass or transparent plastic. Alternatively, the receiving cylinder may be placed in a thermostated bath air circulation chamber.

A2.10 *Residue Cylinder*—The graduated cylinder shall have a capacity of 5 or 10 mL, with graduations into 0.1 mL subdivisions, beginning at 0.1 mL. The top of the cylinder may be flared, the other properties shall conform to Specification E 1272.

A3. DETERMINATION OF THE DIFFERENCE IN LAG TIME BETWEEN AN ELECTRONIC TEMPERATURE MEASUREMENT SYSTEM AND A MERCURY-IN-GLASS THERMOMETER

A3.1 The response time of an electronic temperature measuring device is inherently more rapid than that of a mercury-in-glass thermometer. The temperature measuring device assembly in general use, consisting of the sensor and its casing, or an electronic system and its associated software, or both, is so designed that the temperature measuring system will simulate the temperature lag of the mercury-in-glass thermometer.

A3.2 To determine the difference in lag time between such a temperature measuring system and a mercury-in-glass thermometer, analyze a sample such as gasoline, kerosene, jet fuel, or light diesel fuel with the electronic temperature measurement system in place and in accordance with the procedures described in this test method. In most cases this is the standard distillation step performed with an automated unit.

A3.2.1 Do not use a single pure compound, a very narrow boiling range product, or a synthetic blend of less than six compounds for this test.

A3.2.2 Best results are obtained with a sample that is typical of the sample load of the laboratory. Alternatively, use a full-range mixture with a 5 to 95 % boiling range of at least 100°C.

A3.3 Replace the electronic temperature measuring device with a low range or a high range mercury-in-glass thermometer, depending on the boiling range of the sample.

A3.4 Repeat the distillation with this thermometer, and manually record the temperature at the various percent recovered as described in 10.14.

A3.5 Calculate the values for the repeatability for the observed slope ($\Delta T/\Delta V$) for the different readings in the test.

A3.6 Compare the test data obtained using these two temperature measuring devices. The difference at any point shall be equal to, or less than, the repeatability of the method at that point. If this difference is larger, replace the electronic temperature measuring device or adjust the electronics involved, or both.

A4. PROCEDURE TO DETERMINE THE PERCENT EVAPORATED OR PERCENT RECOVERED AT A PRESCRIBED TEMPERATURE READING

A4.1 Many specifications require specific percentages evaporated or recovered at prescribed temperature readings, either as maxima, minima, or ranges. The procedures to determine these values are frequently designated by the terms Exxx or Rxxx, where xxx is the desired temperature.

NOTE A4.1—Regulatory standards on the certification of reformulated gasoline under the complex model procedure require the determination of E 200 and E 300, defined as the percent evaporated fuel at 93.3°C (200°F) and 148.9°C (300°F), respectively. E 158, the percent evaporated at a distillation temperature of 70°C (158°F), is also used in describing fuel volatility characteristics. Other typical temperatures are R 200 for kerosenes and R 250 and R 350 for gas oils, where R 200, R 250, and R 350 are the percent recovered fuel at 200°C, 250°C, and 350°C, respectively.

A4.2 Determine the barometric pressure, and calculate the correction to the desired temperature reading using Eq 3, Eq 4, or Eq 5 for $t = xxx^{\circ}\text{C}$ (or $t_f = xxx^{\circ}\text{F}$).

A4.2.1 *Manual Method*—Determine this correction to 0.5°C (1°F).

A4.2.2 *Automated Method*—Determine this correction to 0.1°C (0.2°F).

A4.3 Determine the expected temperature reading to yield $xxx^{\circ}\text{C}$ (or $xxx^{\circ}\text{F}$) after the barometric correction. To obtain the expected value, add the absolute value of the calculated correction to the desired temperature if the barometric pressure is above 101.3 kPa. If the barometric pressure is below 101.3 kPa, subtract the absolute value of the calculated correction from the desired temperature.

A4.4 Perform the distillation, as described in Section 10, while taking into account A4.5 and A4.6.

A4.5 *Manual Distillation:*

A4.5.1 In the region between about 10°C below and 10°C above the desired expected temperature reading determined in A4.3 record the temperature reading in intervals of 1 volume %.

A4.5.2 If the intent of the distillation is to solely determine the value of E_{xxx} or R_{xxx} , discontinue the distillation after at least another 2 mL of distillate have been collected. Otherwise, continue the distillation, as described in Section 10, and determine the observed loss, as described in 11.1.

A4.5.2.1 If the intent of the distillation is to determine the value of E_{xxx} and the distillation was terminated after about 2 mL of distillate was collected beyond the desired temperature, allow the distillate to drain into the receiving graduate. Allow the contents of the flask to cool to below approximately 40°C and then drain its contents into the receiving graduate. Note the volume of product in the receiving graduate to the nearest 0.5 mL at 2 min intervals until two successive observations agree.

A4.5.2.2 The amount recovered in the receiving graduate is the percent recovery. Determine the amount of observed loss by subtracting the percent recovery from 100.0.

A4.6 Automated Distillation:

A4.6.1 In the region between about 10°C below and 10°C above the desired expected temperature reading determined in A4.3, collect temperature-volume data at 0.1 volume % intervals or less.

A4.6.2 Continue the distillation, as described in Section 10, and determine the percent loss, as described in 11.1.

A4.7 Calculations:

A4.7.1 *Manual Method*—If a volume % recovered reading is not available at the exact temperature calculated in A4.3, determine the percent recovered by interpolation between the two adjacent readings. Either the linear, as described in 11.6.1, or the graphical procedure, as described in 11.6.2, is permitted. The percent recovered is equal to R_{xxx} .

A4.7.2 *Automated Method*—Report the observed volume to 0.1 volume % corresponding to the temperature closest to the expected temperature reading. This is the percent recovered, or R_{xxx} .

A4.7.3 *Manual and Automated Methods*—To determine the value of E_{xxx} , add the observed loss to the percent recovered, R_{xxx} , as determined in A4.7.1 or A4.7.2 and as described in Eq 9.

A4.7.3.1 As prescribed in 12.6, do not use the corrected loss.

A4.8 Precision:

A4.8.1 The statistical determination of the precision of the volume % evaporated or recovered at a prescribed temperature has not been directly measured in an interlaboratory program. It can be shown that the precision of the volume % evaporated or recovered at a prescribed temperature is equivalent to the precision of the temperature measurement at that point divided by the rate of change of temperature versus volume % evaporated or recovered. The estimation of precision becomes less precise at high slope values.

A4.8.2 Calculate the slope or rate of change in temperature reading, S_C (or S_F), as described in 13.2 and Eq 11 and using temperature values bracketing the desired temperature.

A4.8.3 Calculate the repeatability, r , or the reproducibility, R , from the slope, S_C (or S_F), and the data in Table 8, Table 9, or Table 10.

A4.8.4 Determine the repeatability or reproducibility, or both, of the volume % evaporated or recovered at a prescribed temperature from the following formulas:

$$r_{\text{volume \%}} = r/S_C (S_F) \quad (\text{A4.1})$$

$$R_{\text{volume \%}} = R/S_C (S_F) \quad (\text{A4.2})$$

where:

- $r_{\text{volume \%}}$ = repeatability of the volume % evaporated or recovered,
- $R_{\text{volume \%}}$ = reproducibility of the volume % evaporated or recovered,
- r = repeatability of the temperature at the prescribed temperature at the observed percent distilled,
- R = reproducibility of the temperature at the prescribed temperature at the observed percent distilled, and
- $S_C(S_F)$ = rate of change in temperature reading in °C (°F) per the volume % evaporated or recovered.

A4.8.5 Examples on how to calculate the repeatability and the reproducibility are shown in Appendix X2.

A5. REPEATABILITY FOR GROUP 0 SAMPLES

A5.1 Differences in duplicate temperature readings for each prescribed percentage point should not exceed the amounts equivalent to 2 mL of distillate at each point in question.

A5.2 The difference, d , in temperature between two readings 2 mL apart for Determination 1 at Volume V is either:

$$d_1 = |T_1(V - 2) - T_1(V)| \quad (\text{A5.1})$$

$$d_2 = |T_1(V + 2) - T_1(V)| \quad (\text{A5.2})$$

A5.2.1 For Determination 2, the two values of d are

$$d_3 = |T_2(V - 2) - T_2(V)| \quad (\text{A5.3})$$

$$d_4 = |T_2(V + 2) - T_2(V)| \quad (\text{A5.4})$$

where:

- $T_x(V)$ = temperature reading of sample x at volume V ,
- $T_x(V + 2)$ = temperature reading of sample x at volume $V + 2$ mL, and
- $T_x(V - 2)$ = temperature reading of sample x at volume $V - 2$ mL.

A5.2.2 To be conservative, we now choose the smallest of these four values, that is,

$$d_{\text{min}} = \text{lowest value of } d_1, d_2, d_3, \text{ or } d_4 \quad (\text{A5.5})$$

A5.2.3 Duplicate temperature readings are deemed to be within the repeatability criterion if

$$|T_1(V) - T_2(V)| \leq d_{\min} \quad (A5.6)$$

APPENDIXES

(Nonmandatory Information)

X1. EXAMPLES ILLUSTRATING CALCULATIONS FOR REPORTING OF DATA

X1.1 The observed distillation data used for the calculation of the examples below are shown in the first three columns of Fig. X1.1.

X1.1.1 Temperature readings corrected to 101.3 kPa (760 mm Hg) pressure (see 11.3) are as follows:

$$\text{correction } (^{\circ}\text{C}) = 0.0009(101.3 - 98.6)(273 + t_c) \quad (X1.1)$$

$$\text{correction } (^{\circ}\text{F}) = 0.00012(760 - 740)(460 + t_f) \quad (X1.2)$$

X1.1.2 Loss correction to 101.3 kPa (see 11.4) are as follows. The data for the examples are taken from Fig. X1.1.

$$\text{corrected loss} = (0.5 + (4.7 - 0.5)/ \quad (X1.3)$$

$$\{1 + (101.3 - 98.6)/8.0\} = 3.6$$

X1.1.3 Recovery correction to 101.3 kPa (see 11.4.1) are as follows:

$$\text{corrected recovery} = 94.2 + (4.7 - 3.6) = 95.3 \quad (X1.4)$$

X1.2 *Temperature Readings at Prescribed Percent Evaporated:*

X1.2.1 Temperature reading at 10 % evaporated (4.7 % observed loss = 5.3 % recovered) (see 11.6.1) are as follows:

$$T_{10E} (^{\circ}\text{C}) = 33.7 + [(40.3 - 33.7) \quad (X1.5)$$

$$(5.3 - 5)/(10 - 5)] = 34.1^{\circ}\text{C}$$

$$T_{10E} (^{\circ}\text{F}) = 92.7 + [(104.5 - 92.7) \quad (X1.6)$$

$$(5.3 - 5)/(10 - 5)] = 93.1^{\circ}\text{F}$$

X1.2.2 Temperature reading at 50 % evaporated (45.3 % recovered) (see 11.6.1) are as follows:

$$T_{50E} (^{\circ}\text{C}) = 93.9 + [(108.9 - 93.9) \quad (X1.7)$$

$$(45.3 - 40)/(50 - 40)] = 101.9^{\circ}\text{C}$$

$$T_{50E} (^{\circ}\text{F}) = 201 + [(228 - 201) \quad (X1.8)$$

$$(45.3 - 40)/(50 - 40)] = 215.3^{\circ}\text{F}$$

X1.2.3 Temperature reading at 90 % evaporated (85.3 % recovered) (see 11.6.1) are as follows:

$$T_{90E} (^{\circ}\text{C}) = 181.6 + [(201.6 - 181.6) \quad (X1.9)$$

$$(85.3 - 85)/(90 - 85)] = 182.8^{\circ}\text{C}$$

$$T_{90E} (^{\circ}\text{F}) = 358.9 + [(394.8 - 358.9) \quad (X1.10)$$

$$(85.3 - 85)/(90 - 85)] = 361.0^{\circ}\text{F}$$

X1.2.4 Temperature reading at 90 % evaporated (85.3 % recovered) not corrected to 101.3 kPa pressure (see 11.6.1) are as follows:

$$T_{90E} (^{\circ}\text{C}) = 180.5 + [(200.4 - 180.5) \quad (X1.11)$$

$$(85.3 - 85)/(90 - 85)] = 181.7^{\circ}\text{C}$$

$$T_{90E} (^{\circ}\text{F}) = 357 + [(392 - 357) \quad (X1.12)$$

$$(85.3 - 85)/(90 - 85)] = 359.1^{\circ}\text{F}$$

NOTE X1.1—Results calculated from $^{\circ}\text{C}$ data may not correspond exactly to results calculated from $^{\circ}\text{F}$ data because of errors in rounding.

% recovered	Barometric pressure				% evaporated	procedure	
	observed 98.6 kPa 740 mm Hg $^{\circ}\text{C}$	$^{\circ}\text{F}$	corrected 101.3 kPa 760 mm Hg $^{\circ}\text{C}$	$^{\circ}\text{F}$		arithmetical	graphical
IBP	25.5	78	26.2	79.2	5	26.7	80.0
5	33.0	91	33.7	92.7	10	34.1	93.4
10	39.5	103	40.3	104.5	15	40.7	105.2
15	46.0	115	46.8	116.2	20	47.3	117.1
20	54.5	130	55.3	131.5	30	65.7	150.2
30	74.0	165	74.8	166.7	40	84.9	184.9
40	93.0	199	93.9	201.0	50	101.9	215.3
50	108.0	226	108.9	228.0	60	116.9	242.4
60	123.0	253	124.0	255.1	70	134.1	273.3
70	142.0	288	143.0	289.4	80	156.0	312.8
80	166.5	332	167.6	333.6	85	168.4	335.1
85	180.5	357	181.6	358.9	90	182.8	361.0
90	200.4	393	201.6	394.8	95	202.4	396.3
EP	215.0	419	216.2	421.1			
recovered, %	94.2		95.3				
residue, %	1.1		1.1				
loss, %	4.7		3.6				

FIG. X1.1 Example of Test Report

X2. EXAMPLES OF CALCULATION OF REPEATABILITY AND REPRODUCIBILITY OF VOLUME % (RECOVERED OR EVAPORATED) AT A PRESCRIBED TEMPERATURE READING

X2.1 Some specifications require the reporting of the volume % evaporated or recovered at a prescribed temperature. Table X2.1 shows the distillation data of a Group 1 sample as obtained by an automated unit.

X2.2 *Example Calculation:*

X2.2.1 For a Group 1 sample exhibiting distillation characteristics as per Table X2.1, as determined by an automated unit, the reproducibility of the volume evaporated, R_v volume %, at 93.3°C (200°F) is determined as follows:

TABLE X2.1 Distillation Data from a Group 1 Sample Automated Distillation

Distillation Point Recovered, mL	Temperature° C	Temperature °F	Volume (mL) Recovered at 93.3°C (200°F)
			18.0
10	84	183	
20	94	202	
30	103	217	
40	112	233	

Distillation Point Evaporated, mL	Temperature° C	Temperature °F	Volume (mL) Evaporated at 93.3°C (200°F)
			18.4
10	83	182	
20	94	201	
30	103	217	
40	111	232	

$$S_F \% = 0.1 (T_{(20)} - T_{(10)})$$

$$= 0.1 (201 - 182)$$

$$= 1.9$$

X2.2.2 From Table 9, determine the value of R, the reproducibility at the observed percentage distilled. In this case, the observed percentage distilled is 18 % and

$$R = 3.3 + 2.0 (S_C) \tag{X2.2}$$

$$= 3.3 + 2.0 \times 1.1$$

$$= 5.5$$

$$R = 6.0 + 2.0 (S_F)$$

$$= 6.0 + 2.0 \times 1.9$$

$$= 9.8$$

X2.2.3 From the calculated value of R, determine the value of volume, as described in A4.8.4.

$$R \text{ volume \%} = R/(S_C) \tag{X2.3}$$

$$= 5.5/1.1$$

$$= 5.0$$

$$R \text{ volume \%} = R/(S_F)$$

$$= 9.8/1.9$$

$$= 5.1$$

X2.2.1.1 Determine first the slope at the desired temperature:

$$S_C \% = 0.1 (T_{(20)} - T_{(10)}) \tag{X2.1}$$

$$= 0.1 (94 - 83)$$

$$= 1.1$$

X3. TABLES OF CORRECTED LOSS FROM MEASURED LOSS AND BAROMETRIC PRESSURE

X3.1 The table presented as Fig. X3.1 can be used to determine the corrected loss from the measured loss and the barometric pressure in kPa.

X3.2 The table presented as Fig. X3.2 can be used to determine the corrected loss from the measured loss and the barometric pressure in mm Hg.

Barometric Pressure, kPa

from through	76.1 80.8	80.9 84.4	84.5 87.2	87.3 89.5	89.6 91.4	91.5 93.0	93.1 94.0	94.1 95.4	95.5 96.3	96.4 97.1	97.2 97.8	97.9 98.3	98.4 98.8	98.9 99.4	99.5 99.9	100.0 100.3	100.4 100.7	100.8 101.1	101.2 101.4	101.5 101.9	102.0 102.3	102.4 102.7	102.8 103.1	103.2 103.5
Observed Loss	/-- Corrected Loss ----->																							
Units																								
0	0.37	0.35	0.33	0.31	0.29	0.27	0.25	0.23	0.20	0.18	0.16	0.14	0.13	0.11	0.09	0.06	0.04	0.02	-0.00	-0.02	-0.06	-0.09	-0.13	-0.17
1	0.63	0.65	0.67	0.69	0.71	0.73	0.75	0.78	0.80	0.82	0.84	0.86	0.87	0.89	0.92	0.94	0.96	0.98	1.00	1.03	1.06	1.09	1.13	1.17
2	0.89	0.95	1.01	1.08	1.14	1.20	1.26	1.33	1.40	1.46	1.52	1.57	1.62	1.68	1.75	1.81	1.87	1.94	2.00	2.08	2.17	2.27	2.38	2.51
3	1.15	1.25	1.36	1.46	1.57	1.67	1.77	1.88	1.99	2.09	2.19	2.28	2.37	2.47	2.58	2.69	2.79	2.90	3.00	3.13	3.29	3.45	3.63	3.84
4	1.41	1.56	1.70	1.84	1.99	2.14	2.28	2.43	2.59	2.73	2.87	3.00	3.12	3.26	3.41	3.58	3.70	3.85	4.00	4.18	4.40	4.63	4.89	5.18
5	1.68	1.86	2.04	2.23	2.42	2.61	2.79	2.98	3.19	3.37	3.55	3.71	3.87	4.05	4.25	4.44	4.62	4.81	5.00	5.23	5.51	5.81	6.14	6.52
6	1.94	2.16	2.39	2.61	2.84	3.08	3.30	3.53	3.78	4.01	4.23	4.42	4.62	4.84	5.08	5.31	5.53	5.77	6.00	6.28	6.63	6.99	7.40	7.86
7	2.20	2.46	2.73	3.00	3.27	3.55	3.80	4.08	4.38	4.65	4.90	5.14	5.37	5.63	5.91	6.18	6.44	6.73	7.00	7.33	7.74	8.17	8.65	9.20
8	2.46	2.76	3.07	3.38	3.70	4.02	4.31	4.63	4.98	5.28	5.58	5.85	6.12	6.41	6.74	7.06	7.36	7.69	8.00	8.38	8.86	9.35	9.90	10.53
9	2.72	3.07	3.41	3.76	4.12	4.49	4.82	5.18	5.57	5.92	6.26	6.56	6.87	7.20	7.57	7.93	8.27	8.65	9.00	9.43	9.97	10.53	11.16	11.87
10	2.98	3.37	3.76	4.15	4.55	4.96	5.33	5.73	6.17	6.56	6.94	7.26	7.62	7.99	8.41	8.81	9.19	9.60	10.00	10.48	11.08	11.71	12.41	13.21
11	3.24	3.67	4.10	4.53	4.97	5.43	5.84	6.28	6.77	7.20	7.61	7.99	8.37	8.78	9.24	9.68	10.10	10.56	11.00	11.53	12.20	12.89	13.67	14.55
12	3.50	3.97	4.44	4.92	5.40	5.90	6.35	6.83	7.36	7.84	8.29	8.71	9.12	9.57	10.07	10.56	11.02	11.52	12.00	12.59	13.31	14.07	14.92	15.89
13	3.76	4.27	4.78	5.30	5.83	6.36	6.86	7.39	7.96	8.47	8.97	9.42	9.86	10.36	10.90	11.43	11.93	12.48	13.00	13.64	14.43	15.25	16.17	17.22
14	4.03	4.58	5.13	5.69	6.25	6.83	7.38	7.94	8.56	9.11	9.64	10.13	10.61	11.15	11.74	12.31	12.85	13.44	14.00	14.69	15.54	16.43	17.43	18.56
15	4.29	4.88	5.47	6.07	6.68	7.30	7.87	8.49	9.15	9.75	10.32	10.85	11.36	11.93	12.57	13.18	13.76	14.40	15.00	15.74	16.66	17.61	18.68	19.90
16	4.55	5.18	5.81	6.45	7.10	7.77	8.38	9.04	9.75	10.39	11.00	11.56	12.11	12.72	13.40	14.06	14.68	15.36	16.00	16.79	17.77	18.79	19.94	21.24
17	4.81	5.48	6.16	6.84	7.53	8.24	8.89	9.59	10.35	11.03	11.68	12.27	12.86	13.51	14.23	14.93	15.59	16.31	17.00	17.84	18.88	19.97	21.19	22.58
18	5.07	5.78	6.50	7.22	7.96	8.71	9.40	10.14	10.94	11.66	12.35	12.99	13.61	14.30	15.07	15.80	16.50	17.27	18.00	18.89	20.00	21.15	22.44	23.91
19	5.33	6.08	6.84	7.61	8.38	9.18	9.91	10.69	11.54	12.30	13.03	13.70	14.36	15.09	15.90	16.68	17.42	18.23	19.00	19.94	21.11	22.33	23.70	25.25
20	5.59	6.39	7.18	7.99	8.81	9.65	10.41	11.24	12.14	12.94	13.71	14.41	15.11	15.88	16.73	17.55	18.33	19.19	20.00	20.99	22.23	23.51	24.95	26.59
Tenths	0.0	0.0	0.0	0.0	0.0	0.0	0.0	0.0	0.0	0.0	0.0	0.0	0.0	0.0	0.0	0.0	0.0	0.0	0.0	0.0	0.0	0.0	0.0	0.0
0.1	0.03	0.03	0.03	0.04	0.04	0.05	0.05	0.06	0.06	0.06	0.07	0.07	0.07	0.08	0.08	0.09	0.09	0.10	0.10	0.11	0.11	0.12	0.13	0.13
0.2	0.05	0.06	0.07	0.08	0.09	0.09	0.10	0.11	0.12	0.13	0.14	0.14	0.15	0.16	0.17	0.17	0.18	0.19	0.20	0.21	0.22	0.24	0.25	0.27
0.3	0.08	0.09	0.10	0.12	0.13	0.14	0.15	0.17	0.18	0.19	0.20	0.21	0.22	0.24	0.25	0.26	0.27	0.29	0.30	0.32	0.33	0.35	0.38	0.40
0.4	0.10	0.12	0.14	0.15	0.17	0.19	0.20	0.22	0.24	0.26	0.27	0.29	0.30	0.32	0.33	0.35	0.37	0.38	0.40	0.42	0.45	0.47	0.50	0.54
0.5	0.13	0.15	0.17	0.19	0.21	0.23	0.25	0.28	0.30	0.32	0.34	0.36	0.37	0.39	0.42	0.44	0.46	0.48	0.50	0.53	0.56	0.59	0.63	0.67
0.6	0.16	0.18	0.21	0.23	0.26	0.28	0.31	0.33	0.36	0.38	0.41	0.43	0.45	0.47	0.50	0.52	0.55	0.58	0.60	0.63	0.67	0.71	0.75	0.80
0.7	0.18	0.21	0.24	0.27	0.30	0.33	0.36	0.39	0.42	0.45	0.47	0.50	0.52	0.55	0.58	0.61	0.64	0.67	0.70	0.74	0.78	0.83	0.88	0.94
0.8	0.21	0.24	0.27	0.31	0.34	0.38	0.41	0.44	0.48	0.51	0.54	0.57	0.60	0.63	0.67	0.70	0.73	0.77	0.80	0.84	0.89	0.94	1.00	1.07
0.9	0.24	0.27	0.31	0.35	0.38	0.42	0.46	0.50	0.54	0.57	0.61	0.64	0.67	0.71	0.75	0.79	0.82	0.86	0.90	0.95	1.00	1.06	1.13	1.20

FIG. X3.1 Corrected Loss from Observed Loss and Barometric Pressure kPa

Barometric Pressure, mm Hg.

	571	607	634	655	672	686	698	706	716	723	729	734	738	742	746	750	753	756	759	762	765	768	771	774	
from	506	533	554	571	585	597	605	615	622	628	633	637	641	645	649	652	655	658	661	664	667	670	673	676	
through	606	633	654	671	685	697	705	715	722	728	733	737	741	745	749	752	755	758	761	764	767	770	773	776	
Observed Loss	/--- Corrected Loss ----->																								
Units	0	0.37	0.35	0.33	0.31	0.29	0.27	0.25	0.23	0.20	0.18	0.16	0.14	0.13	0.11	0.09	0.07	0.05	0.02	-0.00	-0.03	-0.06	-0.09	-0.13	-0.17
	1	0.63	0.65	0.67	0.69	0.71	0.73	0.75	0.77	0.80	0.82	0.84	0.86	0.87	0.89	0.91	0.93	0.95	0.98	1.00	1.03	1.06	1.09	1.13	1.17
	2	0.89	0.95	1.01	1.07	1.14	1.20	1.26	1.32	1.39	1.45	1.51	1.57	1.62	1.68	1.74	1.80	1.86	1.93	2.00	2.08	2.17	2.27	2.38	2.50
	3	1.15	1.25	1.36	1.46	1.56	1.67	1.77	1.87	1.99	2.09	2.19	2.28	2.36	2.46	2.57	2.67	2.77	2.88	3.00	3.13	3.28	3.44	3.63	3.83
	4	1.41	1.55	1.70	1.84	1.99	2.14	2.27	2.42	2.58	2.72	2.86	2.99	3.11	3.25	3.40	3.54	3.68	3.83	4.00	4.19	4.39	4.62	4.88	5.17
	5	1.67	1.86	2.04	2.22	2.41	2.61	2.78	2.97	3.18	3.36	3.54	3.70	3.86	4.03	4.23	4.41	4.59	4.79	5.00	5.24	5.50	5.80	6.13	6.50
	6	1.93	2.16	2.38	2.61	2.84	3.07	3.29	3.52	3.77	3.99	4.21	4.41	4.60	4.82	5.05	5.28	5.50	5.74	6.00	6.29	6.61	6.97	7.38	7.84
	7	2.19	2.46	2.72	2.99	3.26	3.54	3.79	4.07	4.36	4.63	4.88	5.12	5.35	5.60	5.88	6.15	6.41	6.69	7.00	7.34	7.72	8.15	8.63	9.17
	8	2.46	2.78	3.07	3.37	3.69	4.01	4.30	4.62	4.96	5.27	5.56	5.83	6.09	6.38	6.71	7.02	7.32	7.64	8.00	8.40	8.84	9.33	9.88	10.50
	9	2.72	3.06	3.41	3.76	4.11	4.48	4.81	5.17	5.55	5.90	6.23	6.54	6.84	7.17	7.54	7.89	8.23	8.60	9.00	9.45	9.95	10.50	11.13	11.84
	10	2.98	3.36	3.75	4.14	4.54	4.94	5.31	5.71	6.15	6.54	6.91	7.25	7.58	7.95	8.37	8.76	9.14	9.55	10.00	10.50	11.06	11.68	12.38	13.17
	11	3.24	3.66	4.09	4.52	4.96	5.41	5.82	6.26	6.74	7.17	7.58	7.96	8.33	8.74	9.19	9.63	10.05	10.50	11.00	11.56	12.17	12.86	13.63	14.51
	12	3.50	3.96	4.43	4.91	5.39	5.88	6.33	6.81	7.34	7.81	8.26	8.67	9.07	9.52	10.02	10.50	10.96	11.46	12.00	12.61	13.28	14.03	14.88	15.84
	13	3.76	4.27	4.78	5.29	5.81	6.35	6.83	7.36	7.93	8.44	8.93	9.38	9.82	10.31	10.85	11.37	11.87	12.41	13.00	13.66	14.39	15.21	16.13	17.17
	14	4.02	4.57	5.12	5.67	6.24	6.82	7.34	7.91	8.53	9.08	9.61	10.09	10.57	11.09	11.68	12.24	12.78	13.36	14.00	14.71	15.51	16.39	17.38	18.51
	15	4.28	4.87	5.46	6.06	6.66	7.28	7.85	8.46	9.12	9.71	10.28	10.80	11.31	11.88	12.51	13.11	13.68	14.31	15.00	15.77	16.62	17.57	18.63	19.84
	16	4.54	5.17	5.80	6.44	7.09	7.75	8.35	9.01	9.72	10.35	10.95	11.51	12.06	12.66	13.33	13.98	14.59	15.27	16.00	16.82	17.73	18.74	19.88	21.18
	17	4.80	5.47	6.14	6.82	7.51	8.22	8.86	9.56	10.31	10.98	11.63	12.22	12.80	13.45	14.16	14.85	15.50	16.22	17.00	17.87	18.84	19.92	21.13	22.51
	18	5.06	5.77	6.49	7.21	7.94	8.69	9.37	10.11	10.91	11.62	12.30	12.93	13.55	14.23	14.99	15.72	16.41	17.17	18.00	18.93	19.95	21.10	22.38	23.84
	19	5.32	6.07	6.83	7.59	8.36	9.15	9.88	10.65	11.50	12.25	12.98	13.64	14.29	15.02	15.82	16.59	17.32	18.12	19.01	19.98	21.06	22.27	23.64	25.18
	20	5.58	6.37	7.17	7.97	8.79	9.62	10.38	11.20	12.09	12.89	13.65	14.35	15.04	15.80	16.64	17.46	18.23	19.08	20.01	21.03	22.17	23.45	24.89	26.51
Tenths	0.0	0.00	0.00	0.00	0.00	0.00	0.00	0.00	0.00	0.00	0.00	0.00	0.00	0.00	0.00	0.00	0.00	0.00	0.00	0.00	0.00	0.00	0.00	0.00	0.00
	0.1	0.03	0.03	0.03	0.04	0.04	0.05	0.05	0.05	0.06	0.06	0.07	0.07	0.07	0.08	0.08	0.09	0.09	0.10	0.10	0.11	0.11	0.12	0.13	0.13
	0.2	0.05	0.06	0.07	0.08	0.08	0.09	0.10	0.11	0.12	0.13	0.13	0.14	0.15	0.16	0.17	0.18	0.19	0.20	0.21	0.22	0.24	0.25	0.27	0.27
	0.3	0.08	0.09	0.10	0.11	0.13	0.14	0.15	0.16	0.18	0.19	0.20	0.21	0.22	0.24	0.25	0.26	0.27	0.29	0.30	0.32	0.33	0.35	0.38	0.40
	0.4	0.10	0.12	0.14	0.15	0.17	0.19	0.20	0.22	0.24	0.25	0.27	0.28	0.30	0.31	0.33	0.35	0.36	0.38	0.40	0.42	0.44	0.47	0.50	0.53
	0.5	0.13	0.15	0.17	0.19	0.21	0.23	0.25	0.27	0.30	0.32	0.34	0.36	0.37	0.39	0.41	0.43	0.45	0.48	0.50	0.53	0.56	0.59	0.63	0.67
	0.6	0.16	0.18	0.21	0.23	0.25	0.28	0.30	0.33	0.36	0.38	0.40	0.43	0.45	0.47	0.50	0.52	0.55	0.58	0.61	0.64	0.67	0.70	0.74	0.80
	0.7	0.18	0.21	0.24	0.27	0.30	0.33	0.35	0.38	0.42	0.44	0.47	0.50	0.52	0.55	0.58	0.61	0.64	0.67	0.70	0.74	0.78	0.82	0.88	0.93
	0.8	0.21	0.24	0.27	0.31	0.34	0.37	0.41	0.44	0.48	0.51	0.54	0.57	0.60	0.63	0.66	0.70	0.73	0.76	0.80	0.84	0.89	0.94	1.00	1.07
	0.9	0.23	0.27	0.31	0.34	0.38	0.42	0.46	0.49	0.54	0.57	0.61	0.64	0.67	0.71	0.75	0.78	0.82	0.86	0.90	0.95	1.00	1.06	1.13	1.20

FIG. X3.2 Corrected Loss from Observed Loss and Barometric Pressure mm Hg
X4. PROCEDURE TO EMULATE THE EMERGENT STEM ERROR OF A MERCURY-IN-GLASS THERMOMETER

X4.1 When an electronic or other sensor without an emergent stem error is used, the output of this sensor or the associated data system should emulate the output of a mercury-in-glass thermometer. Based on information supplied by four manufacturers of automated Test Method D 86 equipment, the averaged equations shown in X4.2 and X4.3 have been reported to be in use.

X4.1.1 The equations shown in X4.2 have limited applicability and are shown for information purposes only. In addition to the correction for the emergent stem, the electronic sensor and associated data system will also have to emulate the lag in response time observed for mercury-in-glass thermometers.

X4.2 When a low range thermometer would have been used, no stem correction is to be applied below 20°C. Above this temperature, the correction is calculated using the following formula:

$$ASTM\ 7C\ T_{elr} = T_t - 0.000162 \times (T_t - 20^\circ C)^2 \quad (X4.1)$$

X4.3 When a high range thermometer would have been used, no stem correction is to be applied below 35°C. Above this temperature the correction is calculated using the following formula:

$$ASTM\ 8C\ T_{ehr} = T_t - 0.000131 \times (T_t - 35^\circ C)^2 \quad (X4.2)$$

where:

T_{elr} = emulated temperature in °C for low range thermometers,

T_{ehr} = emulated temperature in °C for high range thermometers, and

T_t = true temperature in °C.

SUMMARY OF CHANGES

Subcommittee D02.08 has identified the location of selected changes to this standard since the last issue (D 86-02) that may impact the use of this standard (approved June 10, 2003).

(1) Revised Fig. X1.1.

Subcommittee D02.08 has identified the location of selected changes to this standard since the last issue (D 86-01) that may impact the use of this standard (approved Dec. 10, 2002).

(1) Revised A2.5.2.

(2) Revised A2.6.

ASTM International takes no position respecting the validity of any patent rights asserted in connection with any item mentioned in this standard. Users of this standard are expressly advised that determination of the validity of any such patent rights, and the risk of infringement of such rights, are entirely their own responsibility.

This standard is subject to revision at any time by the responsible technical committee and must be reviewed every five years and if not revised, either reapproved or withdrawn. Your comments are invited either for revision of this standard or for additional standards and should be addressed to ASTM International Headquarters. Your comments will receive careful consideration at a meeting of the responsible technical committee, which you may attend. If you feel that your comments have not received a fair hearing you should make your views known to the ASTM Committee on Standards, at the address shown below.

This standard is copyrighted by ASTM International, 100 Barr Harbor Drive, PO Box C700, West Conshohocken, PA 19428-2959, United States. Individual reprints (single or multiple copies) of this standard may be obtained by contacting ASTM at the above address or at 610-832-9585 (phone), 610-832-9555 (fax), or service@astm.org (e-mail); or through the ASTM website (www.astm.org).