



Standard Specification for Asphalt Roof Coatings – Asbestos-Free¹

This standard is issued under the fixed designation D 4479; the number immediately following the designation indicates the year of original adoption or, in the case of revision, the year of last revision. A number in parentheses indicates the year of last reapproval. A superscript epsilon (ε) indicates an editorial change since the last revision or reapproval.

This standard has been approved for use by agencies of the Department of Defense.

1. Scope

1.1 This specification covers asbestos-free asphalt roof coatings of brushing or spraying consistency.

1.2 The following precautionary caveat pertains only to the test method portion, Section 8, of this specification: *This standard does not purport to address all of the safety problems, if any, associated with its use. It is the responsibility of the user of this standard to establish appropriate safety and health practices and determine the applicability of regulatory limitations prior to use.*

2. Referenced Documents

2.1 ASTM Standards:

- D 4 Test Method for Bitumen Content²
- D 95 Test Method for Water in Petroleum Products and Bituminous Materials by Distillation³
- D 140 Practice for Sampling Bituminous Materials⁴
- D 224 Specification for Smooth-Surfaced Asphalt Roll Roofing (Organic Felt)²
- D 312 Specification for Asphalt Used in Roofing²
- D 449 Specification for Asphalt Used in Damproofing and Waterproofing²
- D 562 Test Method for Consistency of Paints Using the Stormer Viscometer⁵
- D 946 Specification for Penetration-Graded Asphalt Cement for Use in Pavement Construction⁴
- E 1 Specification for ASTM Thermometers⁶

3. Classification

3.1 *Type I* is made from asphalts characterized as self-healing, adhesive, and ductile, and conforming to the requirements of Specification D 312, Type I; Specification D 449, Types I or II; or Specification D 946.

3.2 *Type II* is made from asphalts characterized by high

softening point and relatively low ductility, and conforming to the requirements of Specification D 312 Types II or III; or Specification D 449, Type III.

4. Materials and Manufacture

4.1 Asphalt roof coatings shall consist of an asphalt base, volatile petroleum solvents, and mineral or other stabilizers, or both, excluding asbestos fiber, mixed to a smooth, uniform consistency suitable for application by squeegee, three-knot brush, paint brush, roller, or by spraying.

5. Composition

5.1 Asphalt roof coatings complying with this specification shall conform to the following composition limits:

	min	max
Moisture, %	...	2.5
Nonvolatile matter, %	50	...
Mineral or other stabilizer, or both, Stabilizers, %	5	20
Asphalt, %	40	...

6. Physical Requirements

6.1 *Uniformity*—After a thoroughly stirred sample has stood for 72 h at room temperature $23 \pm 2^\circ\text{C}$ ($73.4 \pm 3.6^\circ\text{F}$) in a closed container, it shall show no separation of solvent or settling that cannot be overcome by moderate stirring.

6.2 *Consistency*—The roof coating shall be of a consistency that will spread readily and permit application by squeegee, brush, roller or spray at the rate of 1.25 m²/litre (50 ft²/gal) on prepared roofing, saturated felt, and metal surfaces at ambient temperatures above 10°C (50°F). Consistency at 25°C (77°F) shall be between 50 and 400 Stormer s/100 revolutions.

6.3 *Behavior at 60°C (140°F)*—The roof coating shall show no evidence of blistering, and sag or slide shall be no greater than 6 mm (¼ in.). Staining or absorption of the coating on the reverse side of the prepared roofing test panel shall not exceed 5 % of the coated area.

6.4 *Pliability at 0°C (32°F)*—There shall be no cracking or separation of the roof coating from the metal.

7. Sampling

7.1 Sample the material from the original containers immediately after stirring to a uniform consistency in accordance with Practice D 140. Restir samples to ensure uniformity immediately before withdrawing portions for individual tests.

¹ This specification is under the jurisdiction of ASTM Committee D-8 on Roofing, Waterproofing, and Bituminous Materials and is the direct responsibility of Subcommittee D08.05 on Solvent-Bearing Bituminous Compounds for Roofing and Waterproofing.

Current edition approved Jan. 15, 1993. Published March 1993. Originally published as D 4479 – 85. Last previous edition D 4479 – 85.

² *Annual Book of ASTM Standards*, Vol 04.04.

³ *Annual Book of ASTM Standards*, Vol 05.01.

⁴ *Annual Book of ASTM Standards*, Vol 04.03.

⁵ *Annual Book of ASTM Standards*, Vol 06.01.

⁶ *Annual Book of ASTM Standards*, Vol 14.03.

8. Test Methods

8.1 *Water*—Test Method D 95.

8.2 *Nonvolatile Matter*—Weigh 10 ± 1 g of coating to the nearest 0.01 g into each of two tared, flat-bottom dishes having a diameter of approximately 64 mm (2.5 in.) and walls 16 mm ($\frac{5}{8}$ in.) high. Heat the dish and contents in an oven at 160 to 166°C (320 to 330°F) until the residue shows a loss of not more than 0.05 g on successive hourly weighings; make each weighing after cooling in a desiccator. Calculate the percent nonvolatile matter from the mass of the residue and the mass of the original sample as follows:

$$\text{Nonvolatile matter, \%} = (R_e/S) \times 100 \quad (1)$$

where

R_e = mass of residue from evaporation, g, and

S = mass of original sample, g.

Record the average of the two separate determinations.

8.3 *Mineral or other Stabilizers, or both, and Asphalt*—Test Method D 4, Procedure No. 2, but substitute trichloroethylene for carbon disulfide. Mineral matter shall be reported as mineral or other stabilizers, or both, bitumen as asphalt. Calculate asphalt as percent of original, X_a , as follows:

$$X_a = N - (100 B/A) \quad (2)$$

where:

N = percent nonvolatile matter from 8.2,

B = net mass of insoluble residue, including corrections, and

A = mass of sample taken.

8.4 *Consistency*:

8.4.1 *Summary of Method*—Consistency is determined using the Stormer Viscometer⁷ and the rate of shear reported in terms of the time required for 100 revolutions of the rotor produced by a specified load (compare with Test Method D 562).

8.4.2 *Apparatus*:⁷

8.4.2.1 *Standard Stormer Viscometer*.

8.4.2.2 *Water Bath*—Test Cup Assembly, without central baffle or thermometer holder.

8.4.2.3 *Rotor*, propeller-type (see Fig. 1).

8.4.2.4 *Slotted Weights and a Suitable Hanger*.

8.4.2.5 *Thermometer*—ASTM Stormer Viscosity Thermometer having a range from 20 to 70°C, and conforming to the requirements for Thermometer 49C as prescribed in Specification E 1.

8.4.2.6 *Stop Watch*.

8.4.3 *Preparation of Apparatus*:

8.4.3.1 Place the Stormer Viscometer on a table or shelf high enough to permit the weight to drop about 1 m (40 in.), or sufficient distance to produce about 125 revolutions of the rotor. Insert the shaft of the propeller-type rotor in the chuck as far as it will go and secure it with the set screw.

8.4.3.2 Raise the water bath-test cup assembly until the

bottom of the test cup just touches the bottom of the rotor blade; then lower the assembly 6 mm ($\frac{1}{4}$ in.). Tighten the set screw on the position collar, if available, while the collar is in contact with the bracket and the assembly, and use this setting to position the cup for all test runs. Using the set screws in the rim of the bath holder, adjust the water bath-test cup assembly so that the cup and rotor are visually concentric.

8.4.3.3 For convenience in weight adjustment, attach a slotted metal can cover approximately 50 mm (2 in.) in diameter to the hanger to support the slotted weights required.

8.4.4 *Calibration*:

8.4.4.1 Use a 94.85 % by weight aqueous glycerin solution as a calibration standard. Determine the initial concentration of reagent grade glycerin by accurately measuring its specific gravity (refer to the Appendix), and then add additional water to make up the desired total of 5.15 % by weight water.

8.4.4.2 Determine the weight on the viscometer cord (approximately 100 g) required to produce 100 revolutions of the rotor in the glycerin calibration standard at $25 \pm 0.2^\circ\text{C}$ in 18.0 ± 0.2 s. Check the calibration periodically, particularly after prolonged use of the instrument, and recalibrate as necessary.

8.4.5 *Procedure*:

8.4.5.1 Remove the test cup and fill it with the sample to a level that will extend 6 mm ($\frac{1}{4}$ in.) above the top of the rotor blade. Agitate the sample in the cup thoroughly to remove any trapped air bubbles. Place the test cup in the water bath, and then move the assembly up into test position against the preset collar.

8.4.5.2 Add 450 g to the calibration weight on the cord determined in 8.4.4.2. This will be the test load or driving weight.

8.4.5.3 Adjust the temperature of the sample and the entire test assembly to $25 \pm 0.2^\circ\text{C}$. To expedite reaching equilibrium, raise the driving weight and release the brake to provide agitation. When the water bath, test cup, sample, and rotor have all reached $25 \pm 0.2^\circ\text{C}$, remove the thermometer.

8.4.5.4 Raise the driving weight on the cord so that it nearly touches the pulley. With stop watch in hand, release the brake and observe the moving pointer. After 8 to 10 revolutions have been made, time the next 100 revolutions. Take the average of at least three determinations and record as the Stormer consistency in s/100 revolutions. Record the total driving weight.

8.4.5.5 Consistencies of up to approximately 100 s/100 revolutions shall be determined directly by timing 100 revolutions. For higher consistencies, when timing 100 revolutions might unduly prolong the test, calculate the time required for 100 revolutions from direct measurement of the time required for no less than 25 revolutions.

8.5 *Behavior at 60°C (140°F)*:

8.5.1 Prepare two test specimens with each base by brushing roof coating on two 150 by 150-mm (6 by 6-in.) steel panels and two pieces of smooth surface asphalt roll roofing, each covered by a 0.8-mm ($\frac{1}{32}$ -in.) ± 10 % thick mask with a 75 by 125-mm (3 by 5-in.) opening in the center. The steel panels shall be 0.40 to 0.32-mm (28 to 30-gage) nominal thickness, with clean surfaces free of oil and scale, and capable of being bent smoothly 180° around a 25-mm (1-in.) mandrel. The smooth surface asphalt roll roofing shall conform to the

⁷ Stormer Viscometers available from at least the following: Fisher Scientific Co., various cities; Van Waters and Rogers, various cities; Scientific Products, various cities; and Arthur H. Thomas Co., Philadelphia, PA. Arthur H. Thomas Co., 1974 catalog numbers: 9730-G15 (see 8.4.2.1), 9731-C20 (see 8.4.2.2), 9731-D55 (see 8.4.2.3), 9731-G30 (included with 9730-G15 above).

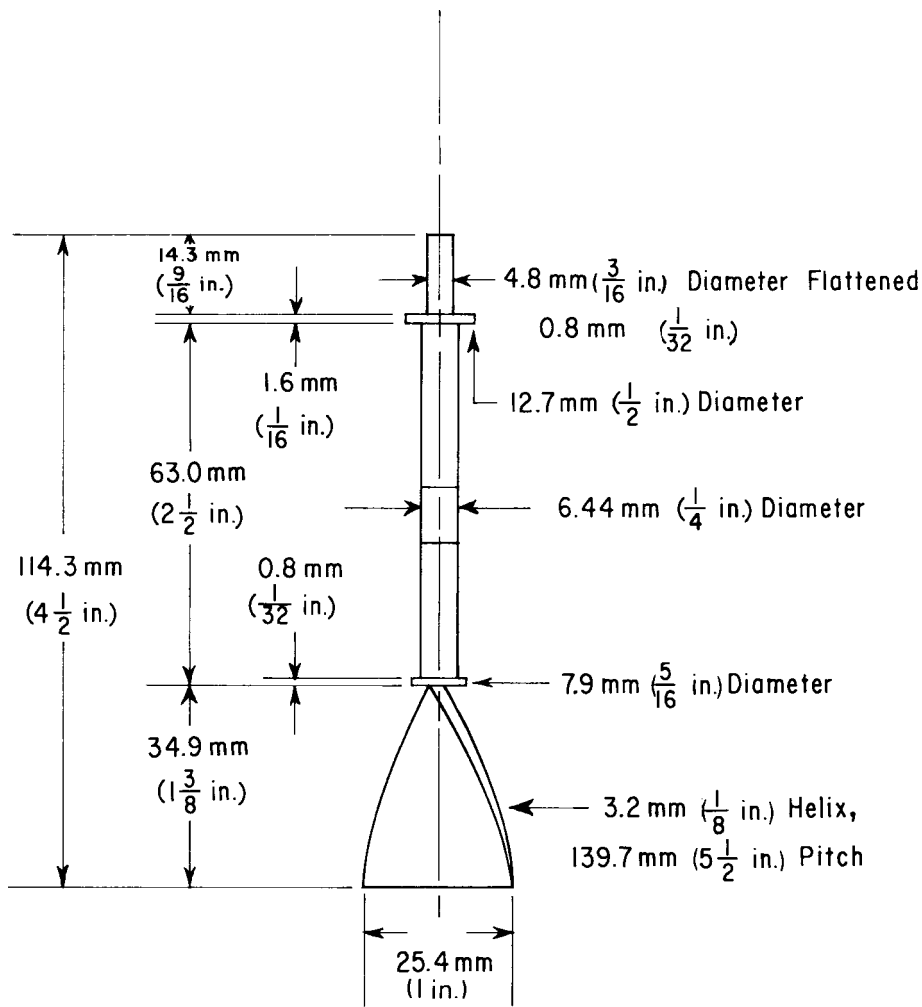

NOTE 1—All dimensions are subject to a tolerance of ± 0.1 mm (± 0.004 in.). Material: nickel-plated brass or stainless steel.

FIG. 1 Propeller-Type Rotor for Use with Stormer Viscometer

requirements of Specification D 224.

8.5.2 Immediately after brushing the coating on the test panels, remove the mask and embed a thread in each coating across the 75-mm (3-in.) dimension, parallel to and no more than 50 mm (2 in.) from one edge of the coating. Measure the distance of the thread from the edge of each test panel to the nearest 1 mm ($1/32$ in.).

8.5.3 Expose the test panels horizontally in a well-ventilated area for 60 min at $23 \pm 2^\circ\text{C}$ ($73.4 \pm 3.6^\circ\text{F}$), but not in direct sunlight.

8.5.4 Suspend the panels vertically with the thread closest to the top edge in an oven at $60 \pm 2^\circ\text{C}$ ($140 \pm 3.6^\circ\text{F}$). After 5 h, remove the test panels from the oven and examine for any sign of blistering. Then measure to the nearest 1 mm ($1/32$ in.) the distance of the thread from the edge of each panel again to determine the extent of any sagging or sliding. Average the two determinations from each type panel. Report results to the nearest 1 mm ($1/32$ in.).

8.5.5 Observe and estimate to the nearest 5% the area stained on the reverse side of the prepared roofing panel due to the absorption of the roof coating.

8.6 *Pliability at 0°C (32°F):*

8.6.1 Cool the coated metal panels from the preceding test to room temperature, and then immerse them in a water bath at 0°C (32°F) for 1 h.

8.6.2 Remove the panels from the water bath and immediately bend them over a 25-mm (1-in.) diameter mandrel through 180° . The bending shall be accomplished in approximately 2 s at a uniform rate, with the metal side of the test panel against the mandrel.

8.6.3 Immediately after bending, dry the panels thoroughly and examine the coating visually for cracking or bond failure. Ignore cracks less than 3 mm ($1/8$ in.) long unless they extend to the metal.

9. Precision and Bias

9.1 The precision of the test methods used in this specification has not been determined.

10. Inspection

10.1 Inspection of the material shall be agreed upon by the purchaser and the seller as part of the purchase contract.

11. Rejection and Rehearing

11.1 Failure to conform to any of the requirements prescribed in this specification shall constitute grounds for rejection. In cases of rejection, the seller shall have the right to reinspect and resubmit the lot after removal of those packages

not conforming to the specified requirements.

12. Keywords

12.1 asbestos-free; asphalt; fibered; roof coating

APPENDIX

(Nonmandatory Information)

X1. SPECIFIC GRAVITY OF AQUEOUS GLYCERIN SOLUTIONS

X1.1 Aqueous solutions of glycerin are suitable liquids for use as standards in calibrating the Stormer Viscometer. By means of an accurate specific gravity determination, the percent glycerin concentration can be determined within ± 0.02 .⁸

⁸ Taken from *Handbook of Chemistry and Physics*, 30th Ed., Chemical Rubber Publishing Co., 19801 Cranwood Parkway, Cleveland, OH 44128, 1948, p. 1742. See also Sheeley, M. L., *Industrial and Engineering Chemistry*, IECHA, Vol 24, 1932, p. 1060.

Sp Gr, ⁸ 25/25 C	Glycerin, weight %
1.23585	90.00
1.23850	91.00
1.24115	92.00
1.24380	93.00
1.24645	94.00
Sp Gr, ⁸ 25/25C	Glycerin, weight %
1.24910	95.00
1.25165	96.00
1.25425	97.00
1.25685	98.00
1.25945	99.00
1.26201	100.00

The American Society for Testing and Materials takes no position respecting the validity of any patent rights asserted in connection with any item mentioned in this standard. Users of this standard are expressly advised that determination of the validity of any such patent rights, and the risk of infringement of such rights, are entirely their own responsibility.

This standard is subject to revision at any time by the responsible technical committee and must be reviewed every five years and if not revised, either reapproved or withdrawn. Your comments are invited either for revision of this standard or for additional standards and should be addressed to ASTM Headquarters. Your comments will receive careful consideration at a meeting of the responsible technical committee, which you may attend. If you feel that your comments have not received a fair hearing you should make your views known to the ASTM Committee on Standards, at the address shown below.

This standard is copyrighted by ASTM, 100 Barr Harbor Drive, PO Box C700, West Conshohocken, PA 19428-2959, United States. Individual reprints (single or multiple copies) of this standard may be obtained by contacting ASTM at the above address or at 610-832-9585 (phone), 610-832-9555 (fax), or service@astm.org (e-mail); or through the ASTM website (www.astm.org).